

Compaction Rollers (Walk Behind)

OPERATING WEIGHT	476 - 700 kg
GROSS ENGINE POWER	5.4/5.5/6.0 kW (7.2/7.4/8.0 hp)
DRUM WIDTH	650 to 710mm
STATIC LINEAR LOAD	5.3 to 7.2 kg/cm
CENTRIFUGAL FORCE	9.0 to 16.0 kN



COMPACTION ROLLERS

- Single Drum (1-71 and MBR71) or Twin Drum (2-65)
- Drum widths from 650mm to 710mm - Operating weights from 476 to 700 kg.
- Powerful and reliable air cooled engines, with hydrostatic transmission for power.
- Superb service access and easy to service components.
- High quality heavy duty design - "rental tough".
- Heavy duty vibration system with high centrifugal force, frequency and static linear load reduces the number of passes required.
- Ergonomic control lever for simple and easy operation of all functions.

Specifications (Performance)

	1-71	MBR71	2-65
Total Static Basic Weight (kg)	461	500	680
Operating Weight (kg) CECE	476	512	700
Static Linear load (kg/cm)	6.7	7.2	5.3
Frequency - Hz (VPM)	65 (3900)	65 (3900)	62 (3720)
Amplitude (mm)	0.66	0.66	0.55
Centrifugal Force (kN)	9.0	9.0	16.0

1-71 MBR71 2-65

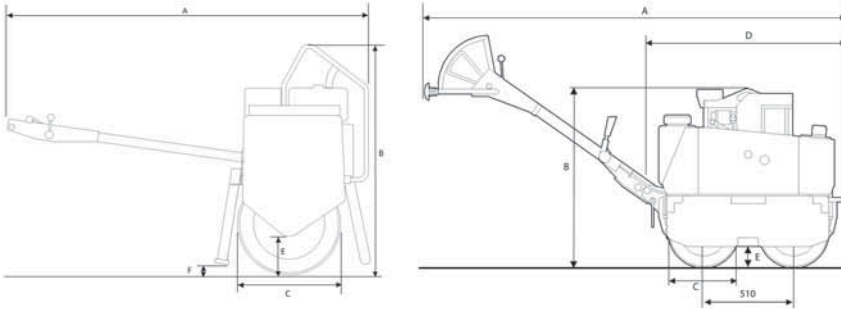
Dimensions

	1-71	MBR71	2-65
A - Overall Length (mm)	2180	2180	2380
B - Overall Height (mm)	1300	1300	1030
C - Drum Diameter (mm)	575	575	400
D - Folded Length (mm)	n/a	n/a	1120
E - Curb Clearance (mm)	230	230	130
F - Ground Clearance (mm)	170	170	n/a
Overhang - Left / Right (mm)	20/110	20/110	100/25
Drum Width (mm)	710	710	650
Drum Shell Thickness (mm)	8.0	8.0	8.0

Engine & Drive

	1-71	MBR71	2-65
Engine Make	Hatz		
Engine Model	1D41S		
Cylinders	1	1	1
Displacement (cc)	413	413	413
Cooling	Air		
Power - kW (HP)	5.4 (7.2)	5.5 (7.4)	6.0 (8.0)
Operating Speed (rpm)	2600		
Fuel Type	Diesel		
Drive	Hydrostatic		
Travel Speed (kph)	3.2	3.2	3.2
Braking System - Service	Dynamic Hydrostatic (via propulsion system)		
Braking System - Parking	Spring Apply / Hydraulic Release		

Capacities

	1-71	MBR71	2-65
Hydraulic Tank Capacity (litres)	n/a	7.5	16
Fuel Tank Capacity (litres)	5	5	5
Water Tank Capacity (litres)	25	20	35

Standard Equipment & Options
Standard Equipment

Gravity Fed Water System
Drum Scraper Bars Front and Rear (both drums on 2-65)
Removable plastic water tank for easy servicing (2-65 only)
Low maintenance battery
Emergency Release Free Wheel Valve (for Towing)* *(1-71 and MBR71 only)
Integral lifting points

Optional Equipment

Hydraulic Breaker attachment, tool, valve and hosing - 30 l/min (MBR71)
Tow behind trailer with breaker storage box (1-71 and MBR71)
Electric starting with Hour Meter

Dealer



TEREX Construction
 Central Boulevard, ProLogis Park,
 Coventry, England CV6 4BX

www.terex.com

PHONE ++44 (0) 2476 339400
 FAX ++44 (0) 2476 339500
 EMAIL enquiries@terexce.com
 WEB www.terexce.com

Effective Date: 19 June 2007. Product specifications and prices are subject to change without notice or obligation. The photographs and/or drawings in this document are for illustrative purposes only. Refer to the appropriate Operator's Manual for instructions on the proper use of this equipment. Failure to follow the appropriate Operator's Manual when using our equipment or to otherwise act irresponsibly may result in serious injury or death. The only warranty applicable to our equipment is the standard written warranty applicable to the particular product and sale and Terex makes no other warranty, express or implied. Products and services listed may be trademarks, service marks or trade-names of Terex Corporation and/or its subsidiaries in the USA and other countries. All rights are reserved. Terex® is a registered trademark of Terex Corporation in the USA and many other countries. © 2010 Terex Corporation.

Ref. no. TEREX522UK

