

AW 240-1140

Static linear loads
from 12.25 to 38 kg/cm

Operating weights
from 2,450 to 14,200 kg



 **Weycor**
BY ATLAS WEYHAUSEN

WEYCOR: POWERFUL, PRECISE, RELIABLE.

POWERFUL COMPACTION TECHNIQUE, RELIABLE QUALITY.

weycor tandem and compaction rollers vouch for technical excellence, for powerful and reliable machines and for quality "Made in Germany". In their respective domain, they exceed the currently applicable emission standards.

In order to highlight these features, for the first time ever, we decided to provide the new ATLAS Weyhausen model series with its own unique name: "weycor". The first syllable refers to the name of the founder of our company and his family, "Weyhausen". The second syllable is derived from the English term "core".

"We are convinced that the new tandem and compaction rollers will soon be an essential part - the "core" - of every construction site." In this sense, "weycor" also defines the key competencies of our successful family business: for more than forty years, our passion for construction machinery has been at the core of our production, and we keep putting our heart and soul into our products!

TABLE OF CONTENTS

weycor.....	2
Tandem rollers	4
Technical highlights.....	4
AW 240.....	5
AW 260.....	6
AW 300.....	7
Compaction rollers	8
Technical highlights.....	8
Vibratory system	10
Engines and traction	12
AW 1070.....	14
AW 1110.....	15
AW 1120.....	16
AW 1130.....	17
AW 1140.....	18
Configuration variants	19
Product range	20



TECHNICAL HIGHLIGHTS

GREATEST DRUM DIAMETER IN THIS WEIGHT CLASS

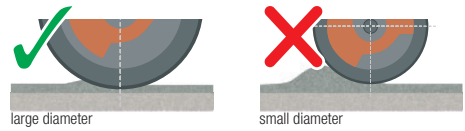

The practice has shown that a larger drum diameter has positive effects on the evenness after the compaction process. This is, among other, proven by the following formula:

$$N = \frac{\text{static linear load in kg/cm}}{\text{Bandages diameter in cm}} = \text{kg/cm}^2$$

Here is vividly illustrated that the lower the result is, the more is the load on the hot asphalt surface reduced. This load reduction prevents against the well known micro-grooves in the transverse direction.

LARGEST WATER TANK IN THIS WEIGHT CLASS

Sprinkler system with pump and interval timer as standard:

Economical water lubrication on the drum surface as long as possible without interruption to compact the hot asphalt as long as needed without sticking on the drum surface.

VIBRATION FRONT AND REAR AS STANDARD ACTIVATED SEPARATELY

Allows sensitive compaction in the first crossings.

FOLDING ROPS STANDARD

For a low transport height.

DECOUPLED OPERATING PLATFORM

Fatigue-free operation of the machine without disability by decoupling from the frame.

NO LUBRICATING POINTS

All pivot points of the roller are adapted for life not be lubricated to need, which turns into time and money savings.

VIBRATION AUTOMATIC STANDARD

To avoid cross-grooves when change direction, the vibration is switched off briefly at the moment of direction change and then automatically re-enabled.

DRUM OFFSET

The front drum is offset by 50 mm to the right side and therefore creating more room for steering corrections when flush compaction on edges are necessary.

AW 240

DRIVE

Speed	0–9 km/h
Angular movement	± 12°
Gradeability with vibration	30 %
Gradeability without vibration	35 %
Engine-Model	Deutz
Type	D 2011 L2i
Emission	Tier 3
Fuel capacity	50 l
Hydraulic oil capacity	40 l

SPRINKLER SYSTEM

Tank capacity	210 l
---------------	-------

STANDARD EQUIPMENT

- ROPS roll bar, foldable
- Hydrostatic drive
- Hydrostatic vibration system at both drums
- 2 centrifugal forces, 2 frequencies
- Automatic vibration mode
- Double / single vibration
- Pressurized interval sprinkler system
- Both drums equipped with spring-loaded brakes
- Manual emergency stop switch with touch sensitive switch at the seat
- 2 resilient vulcollan scraper blades per drum
- Spring-mounted driver's compartment
- 4 working headlights
- Laterally slidable driver's seat with arm rests and safety belt
- Lockable dashboard

OPTIONS

- Lighting according to Road Traffic Regulations (STVZO)
- Back up alarm
- Battery main switch
- Rotating beacon
- Edge cutting and pad roller
- Special color
- Environmentally friendly hydraulic fluid

OPERATING DATA AW 240

Operating weight CECE	2,700 kg
Average axle load CECE	1,350 kg
Engine output	22.5 kW (30.6 PS)
Compaction performance	
Average linear drum load	13.50 kg/cm
Amplitude	0.5 mm
Frequency I / II	53 / 61 Hz
Centrifugal force I / II	21.5 / 28 kN
Bandage	
Drum width	1,000 mm
Drum diameter	750 mm
Drum shell thickness	12 mm
Lateral drum offset	50 mm
Sound level	
Average acoustic power-level $L_{pA}^{(1)}$	100.1 dB(A)
Guaranteed acoustic power-level $L_{pA}^{(2)}$	101.0 dB(A)
Sound pressure level $L_{pA}^{(3)}$	83.0 dB(A)
Specific vibration-data	
Hand- / arm- / bodyvibration ⁽⁴⁾	< 2.5 / 0.5 m/s ²

(1) According to 2000/14/EG & appendixes.
 (2) According to 2000/14/EG & appendixes. (3) According to ISO 6396.
 (4) According to ISO 8041.

TECHNICAL DATA AW 240

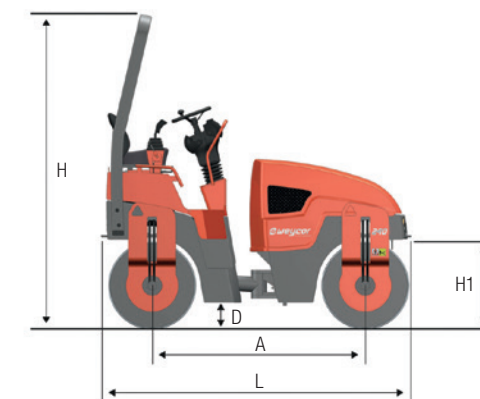

Distance between axes (A)	1,830 mm
Width (B)	1,180 mm
Road clearance (D)	166 mm
Height (H)	2,720 mm
Drum diameter (H1)	750 mm
Length (L)	2,670 mm
Turning radius	
- inside (R)	2,865 mm
- outside (R1)	3,865 mm
Working width (W)	1,050 mm
Drum width (W1)	1,000 mm
Steering angle (α)	±30°

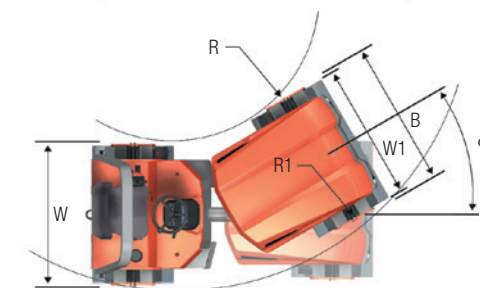

AW 260

DRIVE

Speed 0–9 km/h
Angular movement ± 12°
Gradeability with vibration 30 %
Gradeability without vibration 35 %
Engine-Model Deutz
Type D 2011 L2i
Emission Tier 3
Fuel capacity 50 l
Hydraulic oil capacity 40 l

SPRINKLER SYSTEM

Tank capacity 210 l

STANDARD EQUIPMENT

- ROPS roll bar, foldable
- Hydrostatic drive
- Hydrostatic vibration system at both drums
- 2 centrifugal forces, 2 frequencies
- Automatic vibration mode
- Double / single vibration
- Pressurized interval sprinkler system
- Both drums equipped with spring-loaded brakes
- Manual emergency stop switch with touch sensitive switch at the seat
- 2 resilient vulcollan scraper blades per drum
- Spring-mounted driver's compartment
- 4 working headlights
- Laterally slidable driver's seat with arm rests and safety belt
- Lockable dashboard

OPTIONS

- Lighting according to Road Traffic Regulations (STVZO)
- Back up alarm
- Battery main switch
- Rotating beacon
- Edge cutting and pad roller
- Special color
- Environmentally friendly hydraulic fluid

OPERATING DATA AW 260

Operating weight CECE 2,900 kg
Average axle load CECE 1,450 kg
Engine output 22.5 kW (33.6 PS)

Compaction performance

Average linear drum load 12.08 kg/cm
Amplitude 0.5 mm
Frequency I / II 53 / 61 Hz
Centrifugal force I / II 25 / 34 kN

Bandage

Drum width 1,250 mm
Drum diameter 750 mm
Drum shell thickness 12 mm
Lateral drum offset 50 mm

Sound level

Average acoustic power-level $L_{wA}^{(1)}$ 100.1 dB(A)
Guaranteed acoustic power-level $L_{wA}^{(2)}$ 101.0 dB(A)
Sound pressure level $L_p^{(3)}$ 83.0 dB(A)

Specific vibration-data
Hand- / arm- / bodyvibration⁽⁴⁾ < 2.5 / 0.5 m/s²

(1) According to 2000/14/EG & appendixes.
 (2) According to 2000/14/EG & appendixes. (3) According to ISO 6396.
 (4) According to ISO 8041.

TECHNICAL DATA AW 260

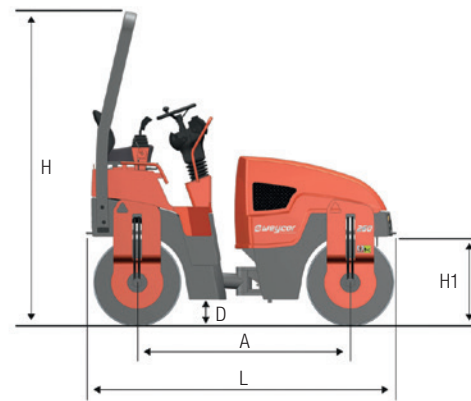

Distance between axles (A)	1,830 mm
Width (B)	1,364 mm
Road clearance (D)	166 mm
Height (H)	2,720 mm
Drum diameter (H1)	750 mm
Length (L)	2,670 mm
Turning radius	
- inside (R)	2,765 mm
- outside (R1)	3,965 mm
Working width (W)	1,250 mm
Drum width (W1)	1,200 mm
Steering angle (α)	±30°

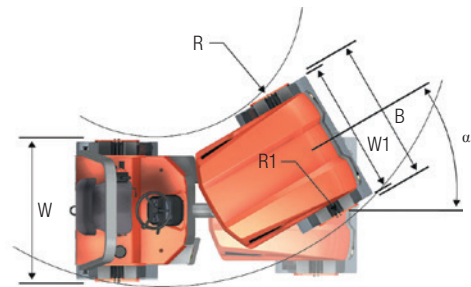

AW 300

DRIVE

Speed 0–9 km/h
Angular movement ± 12°
Gradeability with vibration 30 %
Gradeability without vibration 35 %
Engine-Model Deutz
Type D 2011 L2i
Emission Tier 3
Fuel capacity 50 l
Hydraulic oil capacity 40 l

SPRINKLER SYSTEM

Tank capacity 210 l

STANDARD EQUIPMENT

- ROPS roll bar, foldable
- Hydrostatic drive
- Hydrostatic vibration system at both drums
- 2 centrifugal forces, 2 frequencies
- Automatic vibration mode
- Double / single vibration
- Pressurized interval sprinkler system
- Both drums equipped with spring-loaded brakes
- Manual emergency stop switch with touch sensitive switch at the seat
- 2 resilient vulcollan scraper blades per drum
- Spring-mounted driver's compartment
- 4 working headlights
- Laterally slidable driver's seat with arm rests and safety belt
- Lockable dashboard

OPTIONS

- Lighting according to Road Traffic Regulations (STVZO)
- Back up alarm
- Battery main switch
- Rotating beacon
- Edge cutting and pad roller
- Special color
- Environmentally friendly hydraulic fluid

OPERATING DATA AW 300

Operating weight CECE 3,000 kg
Average axle load CECE 1,500 kg
Engine output 22.5 kW (33.6 PS)

Compaction performance

Average linear drum load 12.00 kg/cm
Amplitude 0.5 mm
Frequency I / II 52 / 58 Hz
Centrifugal force I / II 29 / 37 kN

Bandage

Drum width 1,250 mm
Drum diameter 750 mm
Drum shell thickness 12 mm
Lateral drum offset 50 mm

Sound level

Average acoustic power-level $L_{wA}^{(1)}$ 100.1 dB(A)
Guaranteed acoustic power-level $L_{wA}^{(2)}$ 101.0 dB(A)
Sound pressure level $L_p^{(3)}$ 83.0 dB(A)

Specific vibration-data
Hand- / arm- / bodyvibration⁽⁴⁾ < 2.5 / 0.5 m/s²

(1) According to 2000/14/EG & appendixes.
 (2) According to 2000/14/EG & appendixes. (3) According to ISO 6396.
 (4) According to ISO 8041.

TECHNICAL DATA AW 300

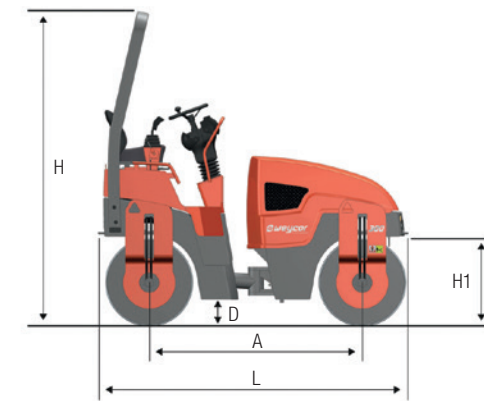

Distance between axles (A)	1,830 mm
Width (B)	1,414 mm
Road clearance (D)	166 mm
Height (H)	2,720 mm
Drum diameter (H1)	750 mm
Length (L)	2,670 mm
Turning radius	
- inside (R)	2,740 mm
- outside (R1)	3,990 mm
Working width (W)	1,300 mm
Drum width (W1)	1,250 mm
Steering angle (α)	±30°

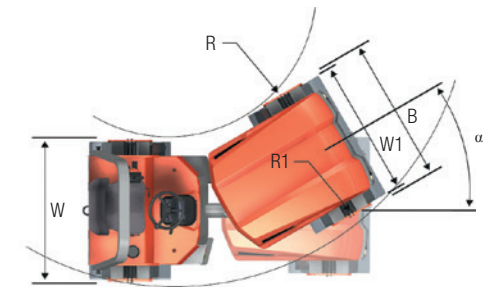

TECHNICAL HIGHLIGHTS



COMFORTABLE PANORAMIC ROPS CABIN

The steering column and the ergonomic arrangement of the operating controls and compaction measurement devices ensure **safe operation and help prevent tiredness**. Special cabin bearings serve to cushion vibrations. **Thanks to her innovative design, the windshield** reflects sound waves and lowers the noise level. In addition, a swiveling seat can be installed as an optional feature. Also available with air conditioning.

360° PANORAMIC VIEW FOR OPTIMAL ON-THE-JOB SAFETY

Excellent circumferential visibility, even in reverse gear, is established by a chamfered engine hood and a very compact design. ROPS cabin with individually adjustable operating elements.



ENGINE

The state-of-the-art low-emission diesel engines that are at work in all weycor compaction rollers are up to the standards set by everyday heavy-duty operation. Substantial power reserves and efficient water cooling serve to spare you trouble, **even at extreme outside temperatures up to 55°C** and on problematic grounds.

Their durability and low fuel consumption account for their cost-effectiveness, their special engine bearings for a noticeable reduction of the noise development.

FRONT FRAME AND DRUM

The entire front frame – with the exception of the crossbeams – is welded in order to ensure maximum stability. On wet and cohesive soils, the optional front and rear scrapers serve to remove accumulated material. The smooth drum can be converted into a pad foot drum by attaching an optional segment kit. The drum unit can easily be dismantled without a lifting tool. The front frame and the drum provide the static force.

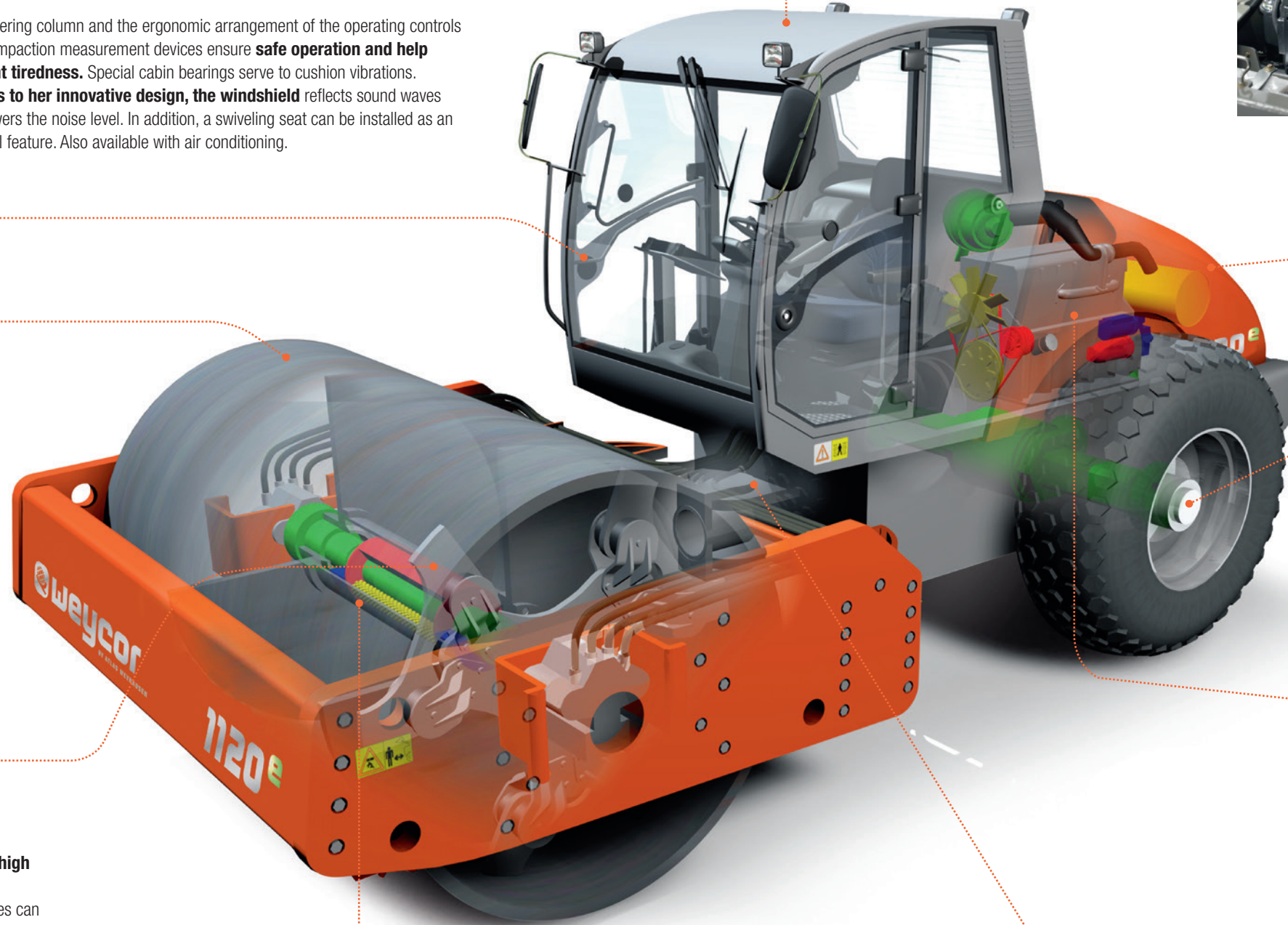

NO-SPIN AXLE

Thanks to its permanent differential lock, **the no-spin axle** provides for the **best traction and maximum climbing power**, which applies to all weycor compaction rollers at all times. Whenever different rotational speeds at the wheels are caused by operation on winding routes, the differential lock is automatically deactivated and will not be re-activated unless the wheels run synchronously again. The no-spin axle is a standard feature of all weycor compaction rollers.

VIBRATION

2-stage vibratory system with high compaction capacity.

Two frequencies and two amplitudes can be selected for surface and deep compaction. Big exterior bearings greased by an oil bath guarantee long inspection intervals.

MAINTENANCE

In order to ensure quick and trouble-free maintenance, all relevant aggregates are easy to reach via the engine hood, which can be opened widely. Maintenance-free or low-maintenance components, such as the vibratory system or the articulated pendulum joint, serve to further reduce the time and effort to be spent on maintenance.

HA-CONTROL

Perfect adaptation to different types of soil is ensured by the **high pressure-dependent control by Bosch-Rexroth**. By double-pump system and a continuous tractive force adjustment automatically provides the **axle and the roller drum with maximum traction** – without any intervention on the part of the driver.

This results in an automatic traction control and a noticeably improved climbing ability, especially in areas such as dike and embankment construction.



ARTICULATED PENDULUM JOINT

All weycor compaction rollers are equipped with **robust, maintenance-free articulated pendulum joints**. They cause the front and the rear end to run in a single track and create a very low center of gravity. With an angle of 35 degrees and a pivoting angle of 12 degrees, an exceptional maneuverability is ensured.

ECO-MODE

This optional feature allows you to use the power of the hydraulic units that the compaction roller is equipped with to full capacity, in a particularly efficient way. Use ECO-Mode to reduce the diesel engine revolution by approx. 400 r.p.m., as compared to the nominal rotation speed, without any loss of power of the hydraulic system. While the vibration frequencies and the centrifugal forces remain constant, **the noise exposure both for the driver and the environment as well as the fuel consumption are reduced by up to 30%**.

weycor tandem rollers – reliable and innovative technology “Made in Germany”.

WEYCOR VIRBRATORY SYSTEM

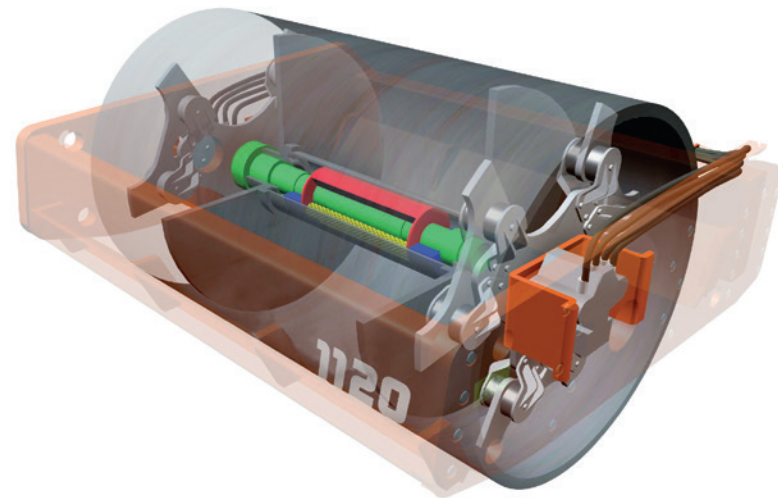

WEYCOR VIBRATORY SYSTEM

The weycor vibratory system is fit to master all types of compaction work. The amount of energy required to achieve the desired degree of compaction can be set by means of two amplitudes and the automatic rotational speed adjustment: High centrifugal forces and a low frequency for deep compaction, lower centrifugal forces and high frequencies for surface compaction. Not only is the weycor vibratory system very robust, but easy to maintain as well: Big exterior bearings greased by an oil bath provide the basis for extra-long maintenance intervals. Thanks to the novel design, none of the bearings is hard to reach any more.

MOST RELEVANT PARAMETERS

(with regard to the efficiency of compaction)

- Overall weight of the machine
- Static linear distributed load
- Oscillating mass
- Amplitude and frequency



A POWERFUL PRINCIPLE

The unbalanced mass is composed of a static and a variable part. The static part consists of a constant flyweight on the shaft while the variable part is created by a staggered housing with a mutable mass. Depending on the rotational direction of the vibratory shaft, the variable mass is added to or subtracted from the constant mass via the flyweight. Thus, a larger or smaller amplitude is created.

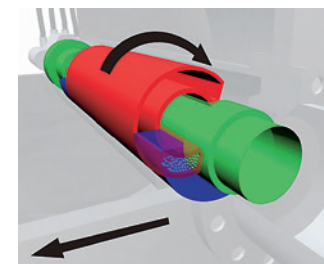

Large amplitude – low rotational speed

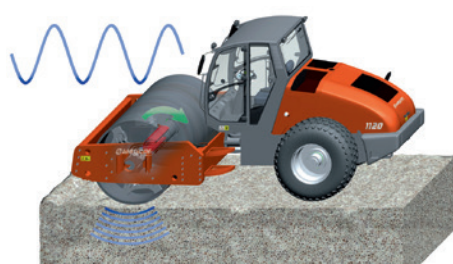

LARGE AMPLITUDE

(fields of application for the compaction of thick layers)

- Non-cohesive and cohesive soils
- Gravel and crushed stone basis
- Hydraulically bonded layers
- Anti-freeze layers
- Substratum
- Dikes, dams

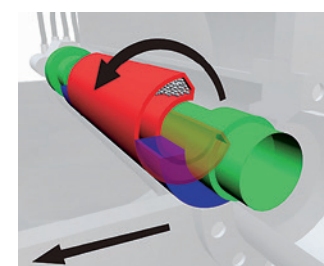

Small amplitude – high rotational speed

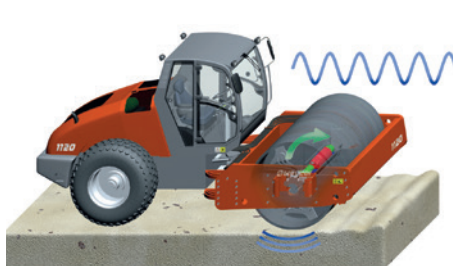

SMALL AMPLITUDE

(fields of application when compacting thin layers)

- Gravel, sand, mixed soils
- Gravel and crushed stone basis
- Surface compaction

COMPACTION PERFORMANCE OF WEYCOR COMPACTION ROLLERS

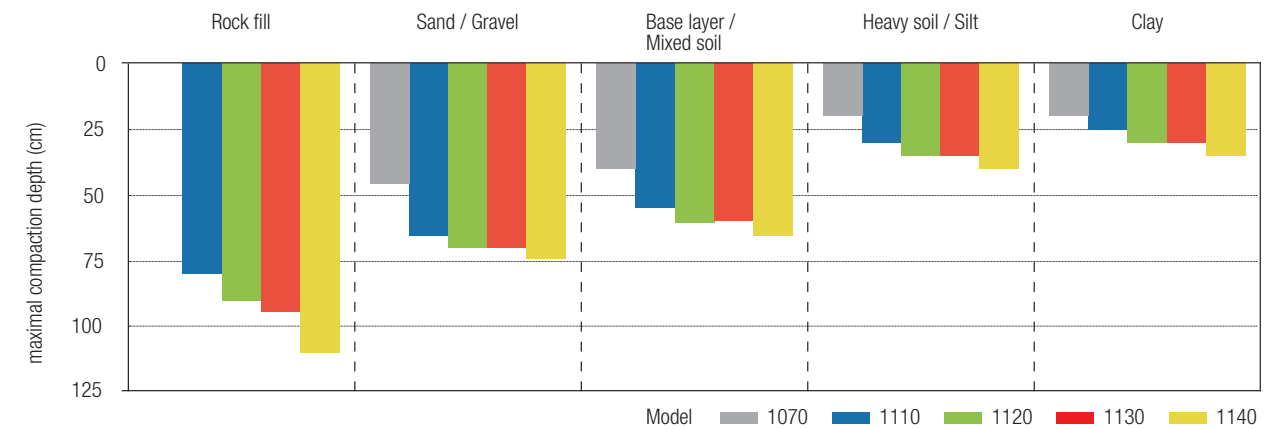

COMPACTION CAPACITY OF WEYCOR SINGLE DRUM ROLLERS

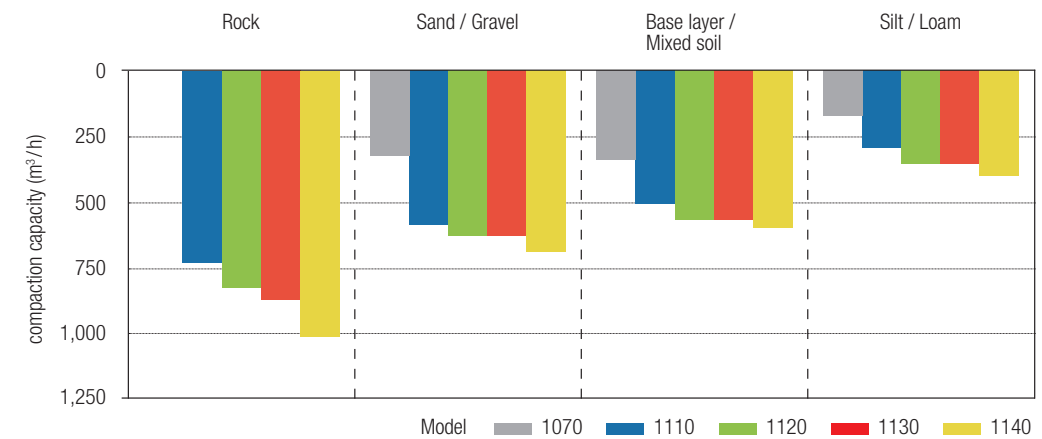

AUTOMATIC COMPACTION MEASUREMENT

On many construction sites, the permanent supervision and/or documentation of the degree of compaction is obligatory. For this purpose, weycor offers different digital systems which record and analyze the entire compaction process.

Without much expenditure of time, potential weak points are easily detected. The system is operated by an acceleration sensor which is mounted to an unmuted part of the drum.



The information gathered by the sensor is digitally transferred to a clearly laid out display in the cockpit. Since the portable device is attached to the drum by a quick-release fastener, it can be used on several machines. The vibration behavior of the drum is recorded by the sensor and serves as the basis for the calculation of the relative compaction value, which is established as the drum is rolling down. Thus, the driver is permanently informed of the current values of all the relevant parameters, such as degree of compaction, amplitude, erratic behavior, frequency and velocity.

All corresponding data are recorded and can either be printed or transferred to a personal computer for subsequent analysis and evaluation.

With the corresponding software, it takes just a few seconds to transfer the entire data recorded by the device to a personal computer, where they are instantly available for further processing.

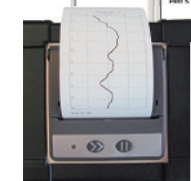
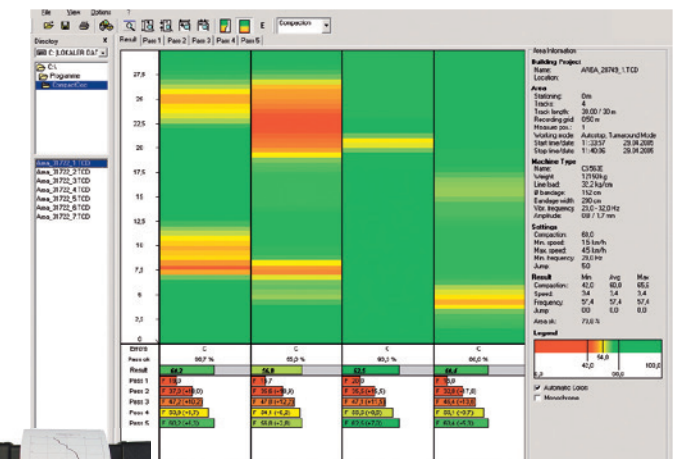

ENGINES AND TRACTION

THE BEST TRACTION – AUTOMATICALLY

In order to adapt the vehicle to different types of soil, the drive units of all weycor compaction rollers are equipped with a high pressure-dependent control. Thanks to the continuous adjustment of the tractive force, maximum traction both at the axle and the roller drum (for type 1070, this applies to the roller drum only) is at your disposal at all times. **As this is an automatic feature, there is no need for the driver to intervene.** In comparison with conventional 4-stage drive units, this system results in **more efficient traction control** and a **noticeably improved climbing ability**, especially in areas such as dike and embankment construction.

THE SAFEST AND STRONGEST WAY TO COMPACT SOIL

Wherever stable grounds and new paths need to be created, weycor compaction rollers take to the job like a duck to water: For road construction jobs, for dikes, for runways and railway lines or operation in landscaping. Our powerful engines and the versatile weycor vibratory system ensure fast, cost-effective work and excellent, presentable results.

With service weights ranging from 2,400 kg to 14,000 kg and state-of-the-art technology, they are ready to meet your compaction challenges:

- Innovative vibratory compaction technology
- Fine-tuning to individual soil features
- Computer-aided supervision and documentation

MORE POWER, LESS CONSUMPTION: ECO-MODE

ECO-Mode, an optional feature, allows for a particularly **efficient exploitation** of the power output of the hydraulic units. This system renders it possible to reduce the motor rotation speed by approx. 400 r.p.m., as compared to the nominal rotation speed, while all parameters regarding the machine's overall performance remain intact.

The intelligent hydraulic system automatically ensures that its resources can still be used to full capacity and both the vibration frequencies and the centrifugal forces remain unaffected. Noticeable outcomes of this innovative, **optimized use** of the hydraulic capacities: Not only does the vehicle consume **less fuel**, but the sound level in the cabin is lowered and hence both the driver's and the environment's noise exposure reduced – without any output losses of the hydraulic system.

It goes without saying that the driver can intervene and manually claim the full capacity of the drive unit at all times.



WEYCOR ECO-MODE

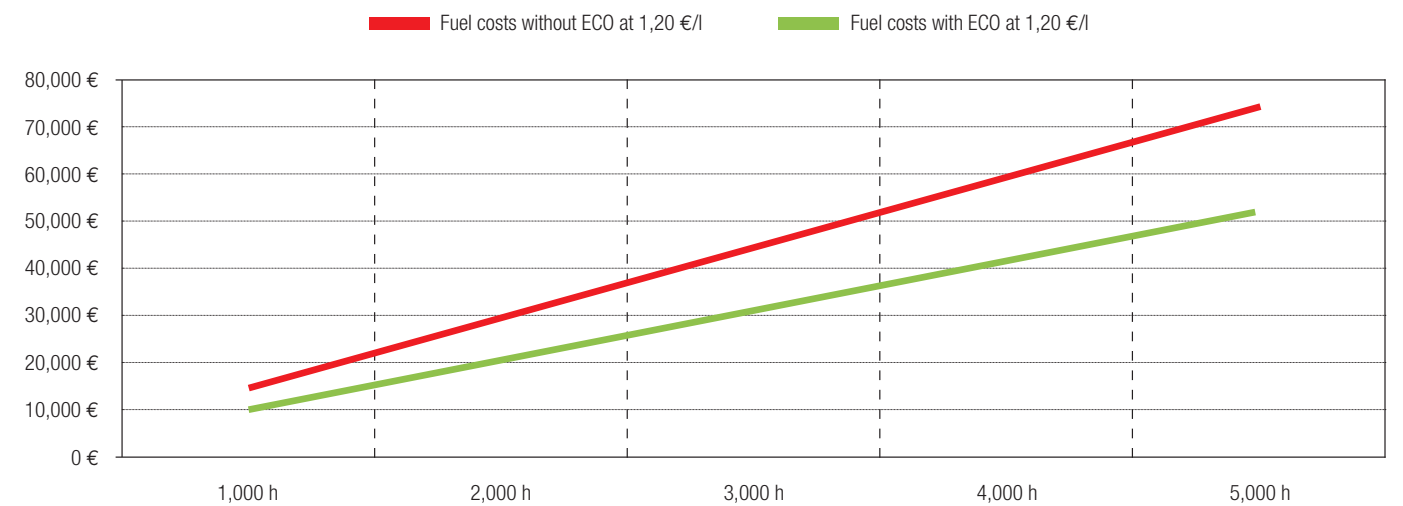

AW 1070

DRIVE

Speed*	0–10 km/h
Angular movement	±12°
Gradeability with vibration	45 %
Gradeability without vibration	50 %
Tyres	16.9–24
Engine-Model	see page 19
Fuel capacity	167 l
Hydraulic oil capacity	68 l

* in HD-Drive 0–12 km/h

STANDARD EQUIPMENT

- ROPS-Cabin with tinted glass, 1 door left and 1 window right, both lockable on 180°
- Maintenance-free centre-pivot steering
- Low-maintenance vibratory system with 2 amplitudes and 2 frequencies
- No-spin rear axle
- Two-stage hydrostatic drive and traction control with anti-slip at the drum (4 stage in HD-Drive)
- Both drives equipped with spring-loaded brake
- Adjustable driver's seat with armrest, adjustable steering column
- Emergency switch
- 4 working headlights
- Hot water heating with fresh-air fan

OPTIONS

- Sunshade Canopy with ROPS bar and waterproof seat
- Air conditioning (for cabin version only)
- Padfoot shell kit (3-part) for modification of a smooth drum
- Spring steel scraper blade (for smooth drum only)
- Vulcolan scraper blade (for smooth drum only)
- Cyclone dust separator
- Battery main switch
- Reverse gear alarm
- Rotating light
- Radio / Radio preparation
- Special colour
- weycor hydraulic fluid (environment-friendly)
- Compaction measurement (digital display)
- Compaction measurement with documentation function
- Preparation for compaction measurement
- Swivable driver's seat
- ECO-Mode
- HD-Drive for more gradeability
- Pad-foot drum

OPERATING DATA AW 1070

Operating weight CECE	7,100 kg *
Weight on front	3,800 kg
Weight on rear	3,300 kg
Engine output	see page 19

Compaction performance

Linear drum load	25.29 kg/cm
Amplitude high / low	1.6 / 0.7 mm
Frequency I / II	30 / 40 Hz
Centrifugal force I / II	120 / 90 kN

Bandage

Drum width	1,700 mm
Drum diameter	1,250 mm
Drum shell thickness	20 mm

Sound level

Average acoustic power-level $L_{wA}^{(1)}$	104.1 dB(A)
Guaranteed acoustic power-level $L_{wA}^{(2)}$	106.0 dB(A)
Sound pressure level $L_p^{(3)}$	76.0 dB(A)
Specific vibration-data Hand- / arm- / bodyvibration ⁽⁴⁾	< 2.5 / 0.5 m/s ²

AW 1070 PD (Pad-foot drum)

Different operating data

Operating weight CECE	7,600 kg *
Weight on front	4,300 kg
Drum diameter	1,140 mm
Gradeability with / without vibration	48 / 53 %
Tyres	16.9–24 TR

(1) According to 2000/14/EG & appendixes.
(2) According to 2000/14/EG & appendixes. (3) According to ISO 6396.
(4) According to ISO 8041.
* Depending on the engine variant.

TECHNICAL DATA AW 1070 AND AW 1070 PD (Pad-foot drum)

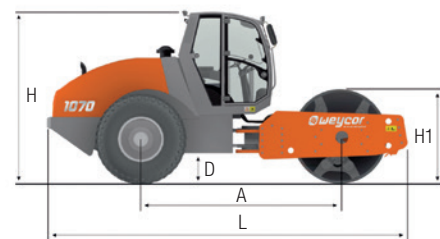

Distance between axles (A)	2,720 mm
Width (B)	1,850 mm
Road clearance (D)	375 mm
Height (H)	2,920 mm
- AW 1070 (H)	2,723 mm
- AW 1070 PD (H)	2,728 mm
Drum diameter	
- AW 1070 (H1)	1,250 mm
- AW 1070 PD (H1)	1,140 mm
Length (L)	5,032 mm
Turning radius	
- inside (R)	3,900 mm
- outside (R1)	5,600 mm
Width about tyres (W)	1,700 mm
Drum width (W1)	1,700 mm
Steering angle (α)	±30°

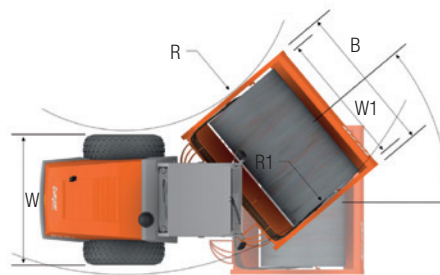

AW 1110

DRIVE

Speed	0–11.5 km/h
Angular movement	±12°
Gradeability with vibration	43 %
Gradeability without vibration	48 %
Tyres	23.1–26
Engine-Model	see page 19
Fuel capacity	300 l
Hydraulic oil capacity	106 l

STANDARD EQUIPMENT

- ROPS-Cabin with tinted glass, 1 door left and 1 window right, both lockable on 180°
- Maintenance-free centre-pivot steering
- Low-maintenance vibratory system with 2 amplitudes and 2 frequencies
- No-spin rear axle
- Four-stage hydrostatic drive and traction control with anti-slip at the drum
- Both drives equipped with spring-loaded brake
- Adjustable driver's seat with armrest, adjustable steering column
- Emergency switch
- 4 working headlights
- Hot water heating with 3-stage fresh-air fan

OPTIONS

- Sunshade Canopy with ROPS bar and waterproof seat
- Air conditioning (for cabin version only)
- Padfoot shell kit (3-part) for modification of a smooth drum
- Spring steel scraper blade (for smooth drum only)
- Vulcolan scraper blade (for smooth drum only)
- Cyclone dust separator
- Battery main switch
- Reverse gear alarm
- Rotating light
- Radio / Radio preparation
- Special colour
- weycor hydraulic fluid (environment-friendly)
- Compaction measurement (digital display)
- Compaction measurement with documentation function
- Preparation for compaction measurement
- Swivable driver's seat
- ECO-Mode
- HD-Drive for more gradeability
- Pad-foot drum

OPERATING DATA AW 1110

Operating weight CECE	11,700 kg *
Weight on front	6,300 kg
Weight on rear	5,400 kg
Engine output	see page 19

Compaction performance

Linear drum load	30.00 kg/cm
Amplitude high / low	1.8 / 0.8 mm
Frequency I / II	30 / 38 Hz
Centrifugal force I / II	220 / 150 kN

Bandage

Drum width	2,100 mm
Drum diameter	1,500 mm
Drum shell thickness	25 mm

Sound level

Average acoustic power-level $L_{wA}^{(1)}$	104.1 dB(A)
Guaranteed acoustic power-level $L_{wA}^{(2)}$	106.0 dB(A)
Sound pressure level $L_p^{(3)}$	77.0 dB(A)
Specific vibration-data Hand- / arm- / bodyvibration ⁽⁴⁾	< 2.5 / 0.5 m/s ²

AW 1110 PD (Pad-foot drum)

Different operating data

Operating weight CECE	12,100 kg *
Weight on front	7,700 kg
Drum diameter	1,390 mm
Gradeability with / without vibration	48 / 52 %
Tyres	23.1–26 TR

(1) According to 2000/14/EG & appendixes.
(2) According to 2000/14/EG & appendixes. (3) According to ISO 6396.
(4) According to ISO 8041.
* Depending on the engine variant.

TECHNICAL DATA AW 1110 AND AW 1110 PD (Pad-foot drum)

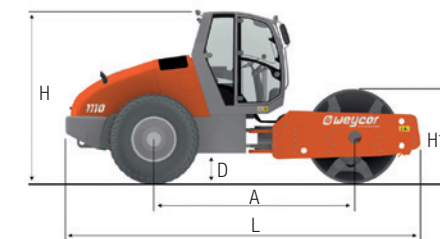

Distance between axles (A)	3,195 mm
Width (B)	2,270 mm
Road clearance (D)	490 mm
Height (H)	2,920 mm
Drum diameter	
- AW 1110 (H1)	1,500 mm
- AW 1110 PD (H1)	1,390 mm
Length (L)	5,757 mm
Turning radius	
- inside (R)	4,860 mm
- outside (R1)	7,015 mm
Width about tyres (W)	2,090 mm
Drum width (W1)	2,100 mm
Steering angle (α)	±30°

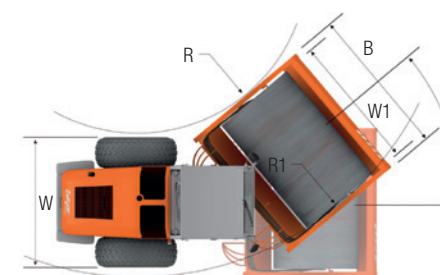

AW 1120

DRIVE

Speed 0–11.5 km/h
Angular movement ±12°
Gradeability with vibration 45 %
Gradeability without vibration 50 %
Tyres 23.1–26
Engine-Model see page 19
Fuel capacity 300 l
Hydraulic oil capacity 106 l

STANDARD EQUIPMENT

- ROPS-Cabin with tinted glass, 1 door left and 1 window right, both lockable on 180°
- Maintenance-free centre-pivot steering
- Low-maintenance vibratory system with 2 amplitudes and 2 frequencies
- No-spin rear axle
- Four-stage hydrostatic drive and traction control with anti-slip at the drum
- Both drives equipped with spring-loaded brake
- Adjustable driver's seat with armrest, adjustable steering column
- Emergency switch
- 4 working headlights
- Hot water heating with 3-stage fresh-air fan

OPTIONS

- Sunshade Canopy with ROPS bar and waterproof seat
- Air conditioning (for cabin version only)
- Padfoot shell kit (3-part) for modification of a smooth drum
- Spring steel scraper blade (for smooth drum only)
- Vulcolan scraper blade (for smooth drum only)
- Cyclone dust separator
- Battery main switch
- Reverse gear alarm
- Rotating light
- Radio / Radio preparation
- Special colour
- weycor hydraulic fluid (environment-friendly)
- Compaction measurement (digital display)
- Compaction measurement with documentation function
- Preparation for compaction measurement
- Swivable driver's seat
- ECO-Mode
- HD-Drive for more gradeability
- Pad-foot drum

OPERATING DATA AW 1120

Operating weight CECE 12,200 kg *
Weight on front 7,100 kg
Weight on rear 5,100 kg
Engine output see page 19

Compaction performance

Linear drum load 33.81 kg/cm
Amplitude high / low 1.8 / 0.6 mm
Frequency I / II 30 / 40 Hz
Centrifugal force I / II 240 / 140 kN

Bandage

Drum width 2,100 mm
Drum diameter 1,500 mm
Drum shell thickness 30 mm

Sound level

Average acoustic power-level $L_{wA}^{(1)}$ 103.9 dB(A)
Guaranteed acoustic power-level $L_{wA}^{(2)}$ 106.0 dB(A)
Sound pressure level $L_p^{(3)}$ 78.0 dB(A)
Specific vibration-data
Hand- / arm- / bodyvibration⁽⁴⁾ < 2.5 / 0.5 m/s²

AW 1120 PD (Pad-foot drum)

Different operating data

Operating weight CECE 13,600 kg *
Weight on front 8,500 kg
Drum diameter 1,390 mm
Gradeability with / without vibration 48 / 52 %
Tyres 23.1–26 TR

(1) According to 2000/14/EG & appendixes.
 (2) According to 2000/14/EG & appendixes. (3) According to ISO 6396.
 (4) According to ISO 8041.
 * Depending on the engine variant.

TECHNICAL DATA AW 1120 AND AW 1120 PD (Pad-foot drum)

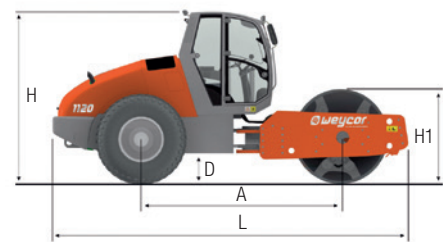

Distance between axes (A)	3,195 mm
Width (B)	2,270 mm
Road clearance (D)	490 mm
Height (H)	2,920 mm
Drum diameter	
- AW 1120 (H1)	1,500 mm
- AW 1120 PD (H1)	1,390 mm
Length (L)	5,757 mm
Turning radius	
- inside (R)	4,860 mm
- outside (R1)	7,015 mm
Width about tyres (W)	2,090 mm
Drum width (W1)	2,100 mm
Steering angle (α)	±30°

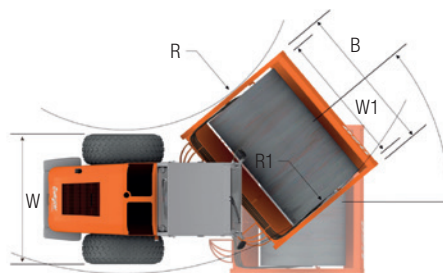

AW 1130

DRIVE

Speed 0–12.5 km/h
Angular movement ±12°
Gradeability with vibration 41 %
Gradeability without vibration 46 %
Tyres 23.1–26
Engine-Model see page 19
Fuel capacity 300 l
Hydraulic oil capacity 106 l

STANDARD EQUIPMENT

- ROPS-Cabin with tinted glass, 1 door left and 1 window right, both lockable on 180°
- Maintenance-free centre-pivot steering
- Low-maintenance vibratory system with 2 amplitudes and 2 frequencies
- No-spin rear axle
- Four-stage hydrostatic drive and traction control with anti-slip at the drum
- Both drives equipped with spring-loaded brake
- Adjustable driver's seat with armrest, adjustable steering column
- Emergency switch
- 4 working headlights
- Hot water heating with 3-stage fresh-air fan

OPTIONS

- Sunshade Canopy with ROPS bar and waterproof seat
- Air conditioning (for cabin version only)
- Padfoot shell kit (3-part) for modification of a smooth drum
- Spring steel scraper blade (for smooth drum only)
- Vulcolan scraper blade (for smooth drum only)
- Cyclone dust separator
- Battery main switch
- Reverse gear alarm
- Rotating light
- Radio / Radio preparation
- Special colour
- weycor hydraulic fluid (environment-friendly)
- Compaction measurement (digital display)
- Compaction measurement with documentation function
- Preparation for compaction measurement
- Swivable driver's seat
- ECO-Mode
- HD-Drive for more gradeability
- Pad-foot drum

OPERATING DATA AW 1130

Operating weight CECE 12,900 kg *
Weight on front 7,200 kg
Weight on rear 5,900 kg
Engine output see page 19

Compaction performance

Linear drum load 34.29 kg/cm
Amplitude high / low 1.8 / 0.9 mm
Frequency I / II 30 / 38 Hz
Centrifugal force I / II 260 / 190 kN

Bandage

Drum width 2,100 mm
Drum diameter 1,500 mm
Drum shell thickness 30 mm

Sound level

Average acoustic power-level $L_{wA}^{(1)}$ 103.9 dB(A)
Guaranteed acoustic power-level $L_{wA}^{(2)}$ 106.0 dB(A)
Sound pressure level $L_p^{(3)}$ 76.0 dB(A)
Specific vibration-data
Hand- / arm- / bodyvibration⁽⁴⁾ < 2.5 / 0.5 m/s²

AW 1130 PD (Pad-foot drum)

Different operating data

Operating weight CECE 13,300 kg *
Weight on front 8,700 kg
Drum diameter 1,390 mm
Gradeability with / without vibration 48 / 52 %
Tyres 23.1–26 TR

(1) According to 2000/14/EG & appendixes.
 (2) According to 2000/14/EG & appendixes. (3) According to ISO 6396.
 (4) According to ISO 8041.
 * Depending on the engine variant.

TECHNICAL DATA AW 1130 AND AW 1130 PD (Pad-foot drum)

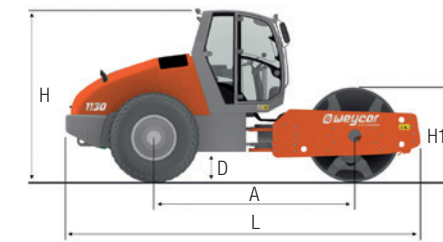

Distance between axes (A)	3,195 mm
Width (B)	2,270 mm
Road clearance (D)	490 mm
Height (H)	2,920 mm
Drum diameter	
- AW 1130 (H1)	1,500 mm
- AW 1130 PD (H1)	1,390 mm
Length (L)	5,757 mm
Turning radius	
- inside (R)	4,860 mm
- outside (R1)	7,015 mm
Width about tyres (W)	2,090 mm
Drum width (W1)	2,100 mm
Steering angle (α)	±30°

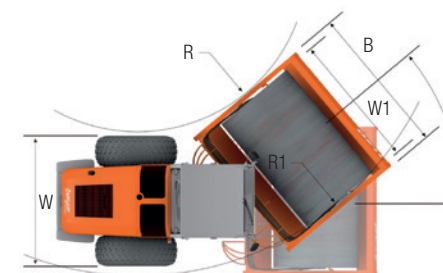

DRIVE

Speed 0–12.5 km/h
 Angular movement ±12°
 Gradeability with vibration 40 %
 Gradeability without vibration 45 %
 Tyres 23.1–26
 Engine-Model see page 19
 Fuel capacity 300 l
 Hydraulic oil capacity 106 l

STANDARD EQUIPMENT

- ROPS-Cabin with tinted glass, 1 door left and 1 window right, both lockable on 180°
- Maintenance-free centre-pivot steering
- Low-maintenance vibratory system with 2 amplitudes and 2 frequencies
- No-spin rear axle
- Four-stage hydrostatic drive and traction control with anti-slip at the drum
- Both drives equipped with spring-loaded brake
- Adjustable driver's seat with armrest, adjustable steering column
- Emergency switch
- 4 working headlights
- Hot water heating with 3-stage fresh-air fan

OPTIONS

- Sunshade Canopy with ROPS bar and waterproof seat
- Air conditioning (for cabin version only)
- Padfoot shell kit (3-part) for modification of a smooth drum
- Spring steel scraper blade (for smooth drum only)
- Vulcolan scraper blade (for smooth drum only)
- Cyclone dust separator
- Battery main switch
- Reverse gear alarm
- Rotating light
- Radio / Radio preparation
- Special colour
- weycor hydraulic fluid (environment-friendly)
- Compaction measurement (digital display)
- Compaction measurement with documentation function
- Preparation for compaction measurement
- Swivable driver's seat
- ECO-Mode
- HD-Drive for more gradeability
- Pad-foot drum

OPERATING DATA AW 1140

Operating weight CECE 14,000 kg *
 Weight on front 8,050 kg
 Weight on rear 5,800 kg
 Engine output see page 19

Compaction performance

Linear drum load 38.33 kg/cm
 Amplitude high / low 1.9 / 0.7 mm
 Frequency I / II 30 / 40 Hz
 Centrifugal force I / II 280 / 180 kN

Bandage

Drum width 2,100 mm
 Drum diameter 1,500 mm
 Drum shell thickness 30 mm

Sound level

Average acoustic power-level $L_{wA}^{(1)}$ 104.8 dB(A)
 Guaranteed acoustic power-level $L_{wA}^{(2)}$ 106.0 dB(A)
 Sound pressure level $L_p^{(3)}$ 76.0 dB(A)
 Specific vibration-data
 Hand- / arm- / bodyvibration⁽⁴⁾ < 2.5 / 0.5 m/s²

AW 1140 PD (Pad-foot drum)

Different operating data

Operating weight CECE 15,400 kg *
 Weight on front 9,500 kg
 Drum diameter 1,390 mm
 Gradeability with / without vibration 48 / 52 %
 Tyres 23.1–26 TR

(1) According to 2000/14/EG & appendices.
 (2) According to 2000/14/EG & appendices. (3) According to ISO 6396.
 (4) According to ISO 8041.
 * Depending on the engine variant.

TECHNICAL DATA AW 1140 AND AW 1140 PD (Pad-foot drum)

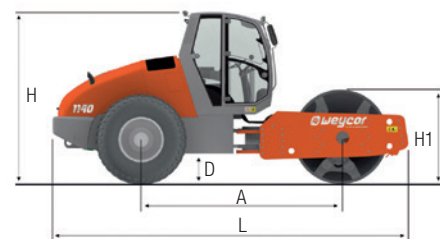

Distance between axles (A)	3,195 mm
Width (B)	2,270 mm
Road clearance (D)	490 mm
Height (H)	2,920 mm
Drum diameter	
- AW 1140 (H1)	1,500 mm
- AW 1140 PD (H1)	1,390 mm
Length (L)	5,757 mm
Turning radius	
- inside (R)	4,860 mm
- outside (R1)	7,015 mm
Width about tyres (W)	2,090 mm
Drum width (W1)	2,100 mm
Steering angle (α)	±30°

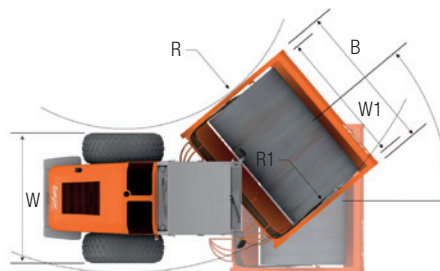

ENGINE AND DRUM VARIANTS

Model	Emission		Smooth drum	Pad-foot drum	Pad-foot shell kit
7-TON-CLASS					
AW 1070 E	Motor Tier 2	1104C-44 / 62 kW (83 HP)	X	X	X
AW 1070	Motor Tier 3	1104D-44T / 62 kW (83 HP)	X	X	X
AW 1070 ^e	Motor Tier 4 interim	TD 2.9 L4 / 54 kW (73 HP)	X	X	X
11-TON-CLASS					
AW 1110 E	Motor Tier 2	BF4M 2012 C / 95 kW (127 HP)	X	X	X
AW 1110	Motor Tier 3	TCD 2012 L4 / 96 kW (130 HP)	X	X	X
AW 1110 ^e	Motor Tier 4 final	Cummins QSF 3.8 / 97 kW (132 HP)	X	X	X
12-TON-CLASS					
AW 1120 E	Motor Tier 2	BF4M 2012 C / 95 kW (127 HP)	X	X	X
AW 1120	Motor Tier 3	TCD 2012 L4 / 96 kW (130 HP)	X	X	X
AW 1120 ^e	Motor Tier 4 final	Cummins QSF 3.8 / 97 kW (132 HP)	X	X	X
13-TON-CLASS					
AW 1130 E	Motor Tier 2	BF4M 2012 C / 100 kW (134 HP)	X	X	X
AW 1130	Motor Tier 3	TCD 2012 L4 / 103 kW (140 HP)	X	X	X
AW 1130 ^e	Motor Tier 4 final	Cummins QSF 3.8 / 97 kW (132 HP)	X	X	X
14-TON-CLASS					
AW 1140 E	Motor Tier 2	BF4M 2012 C / 100 kW (134 HP)	X	X	X
AW 1140	Motor Tier 3	TCD 2012 L4 / 103 kW (140 HP)	X	X	X
AW 1140 ^e	Motor Tier 4 final	Cummins QSF 3.8 / 97 kW (132 HP)	X	X	X

weycor compaction rollers vouch for technical excellence, for powerful and reliable machines and for quality "Made in Germany". In their respective domain, they exceed the currently applicable emission standards. According to the emission regulations of different countries, you have the choice to select the right engine type for your purpose.



PRODUCT RANGE



AW 240

Operation weight CECE	2,700 kg
Linear drum load	13.50 kg/cm
Amplitudes	0.5 mm
Frequency I / II	53 / 61 Hz
Centrifugal force I / II	21.5 / 28 kN



AW 260

Operation weight CECE	2,900 kg
Linear drum load	12.08 kg/cm
Amplitudes	0.5 mm
Frequency I / II	53 / 61 Hz
Centrifugal force I / II	25 / 34 kN



AW 300

Operation weight CECE	3,000 kg
Linear drum load	12.00 kg/cm
Amplitudes	0.5 mm
Frequency I / II	52 / 58 Hz
Centrifugal force I / II	29 / 37 kN



AW 1070^B / AW 1070^B PD*

Operation weight CECE	7,100 / 7,600* kg
Linear drum load	25.29 kg/cm
Amplitudes	1.8 / 0.8 mm
Frequency I / II	30 / 40 Hz
Centrifugal force I / II	120 / 90 kN



AW 1110^B / AW 1110^B PD*

Operation weight CECE	11,700 / 12,100* kg
Linear drum load	30.0 kg/cm
Amplitudes	1.8 / 0.8 mm
Frequency I / II	30 / 38 Hz
Centrifugal force I / II	220 / 150 kN



AW 1120^B / AW 1120^B PD*

Operation weight CECE	12,200 / 13,600* kg
Linear drum load	33.81 kg/cm
Amplitudes	1.8 / 0.6 mm
Frequency I / II	30 / 40 Hz
Centrifugal force I / II	240 / 140 kN



AW 1130^B / AW 1130^B PD*

Operation weight CECE	12,900 / 13,300* kg
Linear drum load	34.29 kg/cm
Amplitudes	1.8 / 0.9 mm
Frequency I / II	30 / 38 Hz
Centrifugal force I / II	260 / 190 kN



AW 1140^B / AW 1140^B PD*

Operation weight CECE	14,000 / 15,400* kg
Linear drum load	38.33 kg/cm
Amplitudes	1.9 / 0.7 mm
Frequency I / II	30 / 40 Hz
Centrifugal force I / II	280 / 180 kN

weycor is an ATLAS WEYHAUSEN GMBH brand.

* Pad-foot drum