

A yellow Hydrema 912FS articulated dump truck is shown in a mining or quarry environment. The truck is positioned on a rocky, uneven terrain, with its front end facing the viewer and its rear end slightly elevated. The truck's body is bright yellow, and the word "HYDREMA" is printed in black on the side of the dump body. The model number "912FS" is visible on the front of the cab. The truck has large, heavy-duty tires and a prominent front grille. The background features a large pile of dark, rocky material under a blue sky with scattered white clouds.

**HYDREMA**

**Hydrema**  
**912F Series**

**ARTICULATED DUMP TRUCKS**

# Innovative earthmoving since 1959

**Since 1959 Hydrema has developed, manufactured, sold and serviced high-tech construction machines. Efficient, innovative and high-quality machines. Our products distinguish themselves from other products on the market through their technical and physical capabilities. Very well suited to perform specialized tasks in construction and installation work.**

 **HYDREMA**





## HYDREMA 912F SERIES

# Compact, highly mobile and off-road superior.

**Articulated compact dump trucks with superb power to weight, durable and easy to operate. Providing efficiency and flexibility - every day, year after year.**

In 1983 Hydrema launched the first compact dump truck. Today these small, agile and robust dump trucks work all over the globe.

### **Stable**

The main reason for the success of the Hydrema 912 dump truck is found in the articulated and oscillating pivot point. The center pivot with hydraulic stabilizers keep the machine stable and safe by automatically transferring the weight to where it is needed for added stability.

The chassis design ensures that the front and rear wheels are running in the same track, and the standard twin tyres gives outstanding traction with minimum ground damage. The pivot, which is centrally pla-

ced, increases maneuverability with a low turning radius of just 6.1 m and great positioning characteristics.

### **Easy to operate**

Operating the 912F is easy and the driver becomes familiar with the machine functions and maneuverability in no time. User-friendly controls, joystick operation, unrivalled visibility and a well-designed cabin, ensures the best working conditions.

A well proven 6 speed ZF Soft-Shift transmission offers full auto or manual shift. This intelligent transmission will automatically shift 2 gears in the right conditions to smoothly increase acceleration regardless of the payload.

### **Strong but fuel efficient**

A state of the art 147 hp Cummins engine offers one of the best power-to-weight ratios on the market. Whether the machine is working on steep gradients or in poor ground conditions, the 912F-series has the power to cope.

The high torque offers more power at lower revs, which improves fuel economy and noise levels. Positive for both environmental and financial reasons.





**Working on poor ground conditions and where space is scarce**

The compact design along with smart features like the swiveling dump body -MultiTip- allow the truck to work on minimal space on narrow and congested sites.

The unique combination of high level of stability, outstanding traction and lots of power provides the 912F-series dump trucks with great driving abilities even in rough, hilly and muddy conditions.

Due to a low net weight the dump truck has very low ground pressure - down to 85 kPa - when carrying a full load of 10 tons. Together with tracking of the wheels this ensures minimal ground damage which is great for working on sensitive surfaces like golf courses, landscaping and for environmental work.

When other dump trucks give up the Hydrema 912 keeps going, giving the operator a major advantage. That is why it is chosen for a wide variety of tasks and jobs with low accessibility.

**Rental friendly**

The 912 dump truck is well-known for its robustness, low maintenance costs and usage in a wide range of applications. The truck is engineered and produced to give many years of solid performance which combined with its ease of operation makes it particularly suitable for rental applications.

**Visible safety**

To increase the visibility of the dump truck, orange flashing LED lights can be mounted both at the front and rear (option). Furthermore, up to 4 rearwards facing LED working lights can be fitted to the dump truck body in order to ease the work during the dark hours.



**ADVANTAGES**

---

High mobility due to center pivot steering and hydraulic stabilizers.

---

Quality made. Heavy duty construction. Build to last.

---

Low weight of the truck provides a very low ground pressure.

---

Strong Cummins QSB 4.5 stage 4 engine with DOC and SCR catalyst. Great torque.

---

User friendly and easy to operate. High operator comfort and safety. Perfect for rental.

**EASY UNLOADING**

# Unloading that works for you.

**The dump truck body is the backbone of the vehicle. The unloading process is optimized through a re-designed body and by utilizing smart features like automatic tipping throttle and MultiTip.**

**Quick unloading**

A tipping time of 6 seconds means the material can be unloaded quickly. The truck is fitted with an automatic tipping-throttle, where the machine will automatically increase the engine speed when the tipping function is activated to quickly raise the body and thereby increase the efficiency.

The ground clearance when tipping is 110 cm, which provides the opportunity to unload the material over edges, or in high piles in order to save space.

The robust body is manufactured in durable high-tensile steel and a rigid frame along the top provides greater stability.

In addition, the body is designed with rounded corners so even wet and sticky material will easily slide off when tipping.

In cases where additional stability is required - for example, loading over the side - the pivot lock can be activated.

**Precise and flexible unloading**

A popular optional feature is the MultiTip, where the dump truck can turn the body 90 degrees to each side and deliver the payload anywhere you want in the 180 degrees area with high precision.

MultiTip makes several working situations easier. For example when tipping a certain amount of payload sideways, whilst moving forward, or into a trench. MultiTip also allows you to work in very narrow conditions.

**Greater efficiency with Auto-Body-Return**

With the (optional) Auto-Body-Return function, the body is automatically lowered back onto the chassis with a push of a button. In other words, the operator does not have to look backwards when the body is being lowered - instead he can move on to the next task while the body lowers itself into the resting position. It saves valuable hours and allows the operator to focus on what happens in front of the truck.

**Stable even on inclines**

The low center of gravity of the 912F series dump trucks and good weight distribution between the chassis parts provide great stability, no matter if the dump truck is carrying load or not.

**Driving on in-clines**  
(Slope angle where the machine overturns).

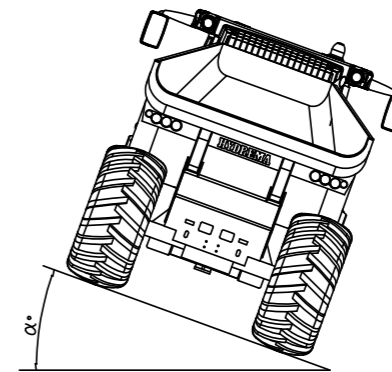

	912F		912FS		912HM	
	EMPTY	LOADED	EMPTY	LOADED	EMPTY	LOADED
Going straight	40°	32°	39°	38°	39°	38°
Turning up-hill	39°	29°	31°	28°	31°	28°





## COMFORT AND SERVICE:

# Optimal visibility, comfort and service access.

### Optimal operator comfort

The spacious cab offers great visibility and a soft touch interior that is easy to clean. All the instrumentation is ergonomically placed and the steering wheel, seat and arm rests are fully adjustable to suit the individual operator.

A joystick is installed as an integrated part of the right armrest. From here you operate the main dumper functions such as tipping, gear selection, forwards / reverse and differential lock. This provides easy control at your fingertips.

An air-conditioning system is incorporated as standard, with 8 air nozzles placed throughout the cab for optimal indoor climate. The cab is also fitted

with automatic entry/exit lighting for safer nighttime operation. To reduce vibration the cab-mountings are spring dampened.

### A great view

The engine is placed behind the cab, which gives the operator an unobstructed forward view from the driver's seat for safer operation. An optional rearview camera provides greater visibility when reversing.

### Front-axle suspension minimizes operator fatigue

The front axle on the 912FS and HM models is equipped with an electro-hydraulic suspension system that provides unprecedented comfort for this type of

machine. The system has independent suspension cylinders and level control of the two front wheels. This reduces the vibration level substantially over a long working day, especially on longer hauls.

The built-in computer automatically adjusts the suspension depending on how much the dumper is loaded so that the vehicle is comfortable to drive both with and without loads.

### Easy service access

Opening the large bonnet gives easy access to the different service points: engine, oil level, hydraulic system, etc. The two front fenders have integrated storage and built-in battery housing.



## MACHINE DATA

# Specifications.

### Chassis

Articulated chassis in a heavy-duty robot-welded construction. 912F has rigid integral axles, whilst the 912FS and 912HM have front axle suspension in heavy-duty pivot bearings and two suspension cylinders. Pivot with pendulum bar and double hydraulic stabilizers with the option of locking the oscillation movement. The pivot is fitted with large spherical pivot bearings. The fuel, AdBlue and hydraulic tanks are integrated into the front chassis. Oscillation: +/- 12°

### Axles

The 912F has fixed, rigid axles. The 912FS and 912HM has electronically suspension cylinders on the front axle. The axles have planetary reduction in the wheel hubs and separate oil reservoirs in the hubs. The front axle has automatic limited-slip differential lock whilst the rear axle has an electro-hydraulically activated 100% differential lock.

### Engine

Cummins QSB 4.5L Stage 4 engine with DOC and SCR catalysts with Ad-Blue additive. 16 valve common rail turbo diesel engine with intercooler, electronically variable turbo charger and EGR with cooling. Max power: 108 kW (147 hp) at 2000 rpm. Max. torque: 597 Nm at 1500 rpm.

### Transmission

ZF WG115 6-speed fully automatic »ERGOPOWER« with full electronic control. 6 forward and 3 reverse gears. Electronically controlled pressure on each clutch ensures completely smooth gear shifts without any loss of tractive effort. Automatic or manual gear shifts; it is possible to shift manually using push buttons on the joystick. Constant 4WD.

### Steering

Hydrostatic Load Sensing pivot steering with 2 double acting cylinders. Priority valve and integrated emergency steering. Steering cylinders with damping. Max. steering angle: +/- 35°

### Hydraulic System

Hydraulic pump with 84 l/min for tipping function and with priority valve for steering function. Separate hydraulic pump for brakes and pivot stabilizers.

### Brakes

Dual-circuit hydraulic servo system with oil-immersed brake discs on each wheel. The brakes are self-adjusted and maintenance-free. The parking brake is a Maintenance-free, »Fail-safe« brake with electro-hydraulic activation of the wet disc brakes on the front axle.

### Cab

Spacious ROPS / FOPS approved cab with cab suspension. Mechanical or air-suspended seat. Adjustable steering wheel and multi-joystick control.

### Body

5.6 m<sup>3</sup> body fabricated in robotically welded high tensile steel.

### Electric System

Standard 24V system with 70 Amp. alternator. Batteries: 2x 12V, 100Ah.

### Noise levels

LpA: 72 dB(A) (inside cab)  
LwA: 102 dB(A) (outside cab)

### Fuel

Diesel: 140 L fuel tank.  
Ad Blue: 14 L tank.  
Integrated into the front chassis.

### MultiTip (optional)

Compact slewing system with rapid unloading at the rear and to both sides. The slewing system is supported in a robust ball-bearing slewing ring. Pivotal movement takes place by means of 2 double acting cylinders. Tipping function by means of 2 double acting cylinders.

# Many machine configurations.

## The 912 F-series dump truck range offers many different options to suit your needs and requirements.

The standard dump truck is the 912F, while the 912FS and 912HM has a suspended front axle. The High-Mobility version - the 912HM - features taller tyres, higher ground clearance and can accommodate up to 800mm wide tyres for minimized ground pressure.

As standard the dump trucks are mounted with a rear tip body and can be fitted with the optional MultiTip, which allows the body to turn through a 180 degrees area. The 912HM is also available with a flatbed body, where the rear chassis is ex-tended to accommodate the in-creased length of the body.

The MultiChassis version is a universal platform where a variety of customized solution can be mounted, such as water tanks, concrete mixers or salt spreaders.

Furthermore, items like brushes and snow blades can be mounted both at the front and on the rear of the truck.

# Dimensions.

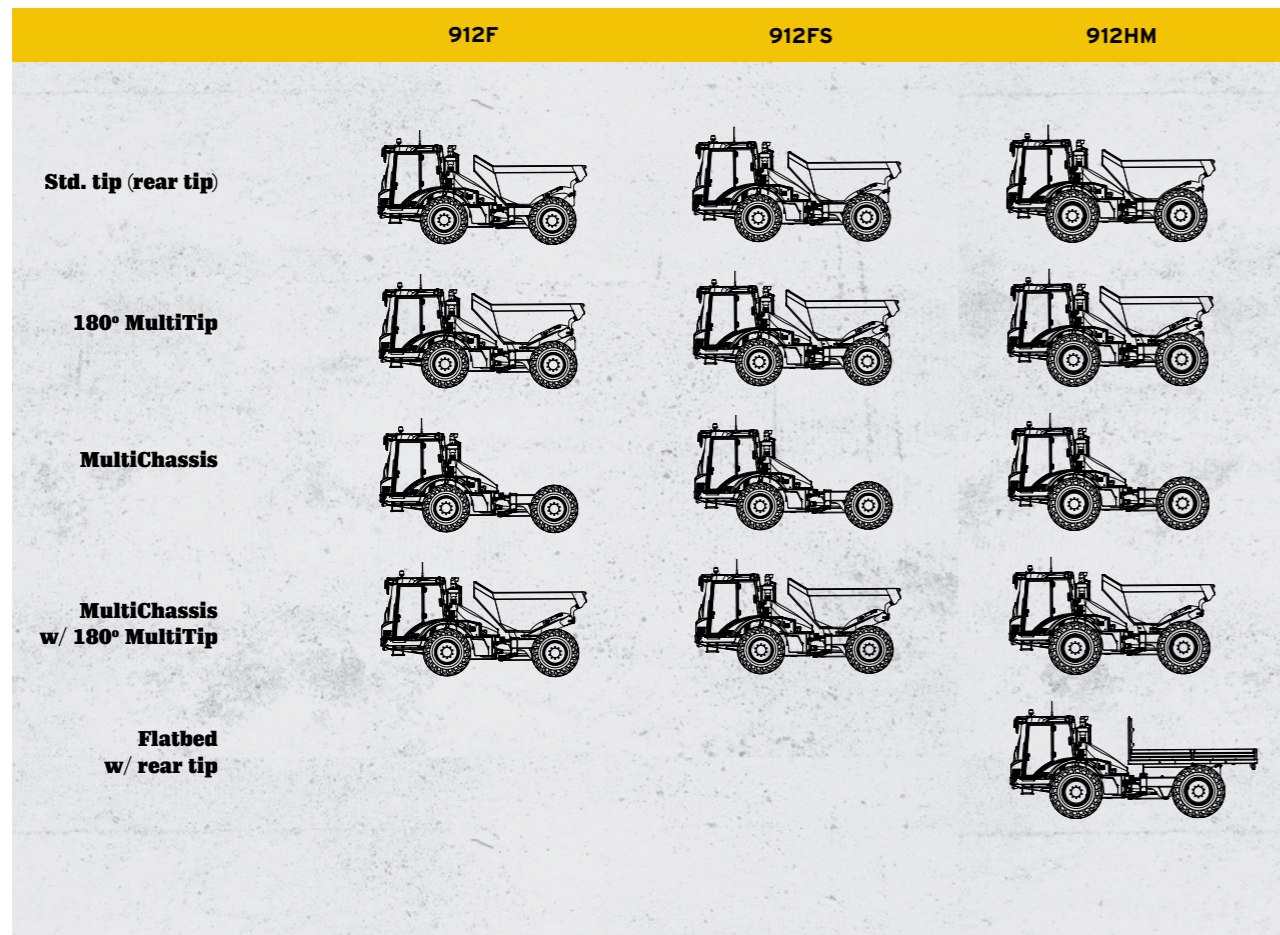
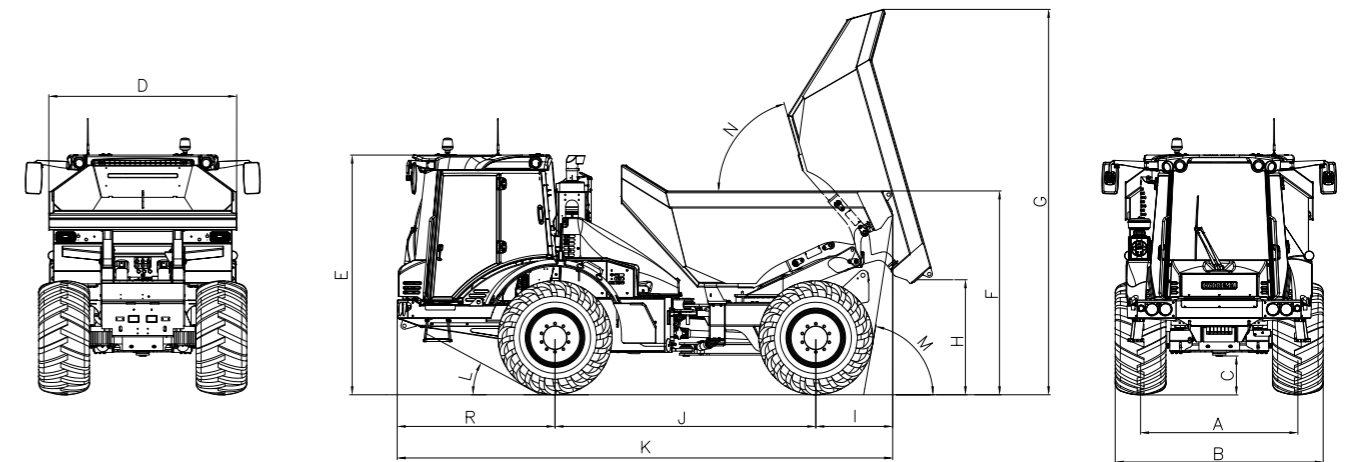

		912F			912FS			912HM				
		STD. TIP	MULTITIP	MULTICHAS.	STD. TIP	MULTITIP	MULTICHAS.	STD. TIP	STD. TIP	MULTITIP	MULTICHAS.	FLATBED
Tires		600/55-26,5	600/55-26,5	600/55-26,5	600/55-26,5	600/55-26,5	600/55-26,5	800/45x30,5	600/60x30,5	800/45x30,5	800/45x30,5	800/45x30,5
Total weight	kg	17270	17730	18000	17540	18000	18000	18260	17970	18720	18000	18260
Unladen weight	kg	7270	7730	6100	7540	8000	6200	8260	7970	8720	6900	8260
Load capacity	kg	10000	10000	11900	10000	10000	11700	10000	10000	10000	11100	10000
Body capacity	m³	5,6	5,6	-	5,6	5,6	-	5,6	5,6	5,6	-	5,6
Turning radius	m	6,1	6,1	6,1	6,1	6,1	6,1	6,3	6,1	6,3	6,3	7,0
Ground pressure (loaded)	kPa	122	123	-	123	125	-	85	113	86	-	85
Suspended front axle					X	X	X	X	X	X	X	X
A. Track	mm	1860	1860	1860	1860	1860	1860	2060	1900	2060	2060	2060
B. Total width	mm	2470	2470	2470	2470	2470	2470	2870	2540	2870	2870	2870
C. Clearance	mm	450	450	450	450	450	450	520	520	520	520	520
D. Dump truck body width	mm	2210	2210	-	2210	2210	-	2210	2210	2210	-	2485
E. Total height	mm	2750	2750	2750	2790	2790	2750	2865	2865	2865	2868	2865
F. Loading height	mm	2225	2390	-	2245	2410	-	2330	2330	2480	-	1950
G. Height with raised body	mm	4385	4550	-	4385	4550	-	4470	4470	4635	-	4330
H. Tipping clearance	mm	1110	1280	-	1110	1280	-	1195	1195	1365	-	400
I. Overhang, rear	mm	990	910	-	990	910	-	990	990	910	-	1675
J. Wheel base, bogie	mm	3080	3080	3080	3080	3080	3080	3080	3080	3080	3080	3480
K. Length	mm	5940	5860	5650	5940	5860	5650	5940	5940	5860	5730	7025
L. Approach angle, front	°	27	27	27	28	28	28	30	30	30	30	30
M. Approach angle, rear	°	75	80	-	75	80	-	80	80	83	-	45
N. Tipping angle	°	75	75	-	75	75	-	75	75	75	-	72
R. Overhang, front	mm	1870	1870	-	1870	1870	-	1870	1870	1870	-	1870



# Well equipped with many options.

## STANDARD EQUIPMENT

### Machine:

Tyres, 912F & 912FS: 600/55 - 26,5 Twin  
 Tyres, 912HM: 600/60 - 30,5 Twin  
 Front axle: Limited slip differential lock  
 Rear axle: 100% electro-hydraulic differential lock  
 Suspended front axle (only 912FS and 912HM)  
 Oscillation of center pivot point

### Cabin:

Green rotating beacon - seatbelt activated  
 12V and 24V plug box in cab  
 Wiper with interval control - front / rear  
 Sunshade - front  
 Handheld light  
 Red lighting effect inside cab (for night use)  
 Sun shield on cap - front  
 Automatic air-conditioning  
 Headrest  
 Rotating beacon  
 Radio with FM  
 Two side mirrors with heating - front  
 Seat heating  
 Automatic driving lights  
 8 Megabeam working lights

### Operation:

Automatic tipping throttle  
 Automatic tipping brake  
 Automatic Lock of oscillation in pivot point when tipping  
 Cruise control  
 Rear view system with monitor in cab

## OPTIONAL EQUIPMENT

### Wheels / Tires:

912F & 912FS:  
 Wheel set; 17.5 x 25 EM  
 912HM:  
 Wheel set: 800/45-30.5  
 Wheel set: 650/65-R25 EM

### Dumper body:

180° Multitip  
 Extended upper body edge  
 Extension of rear body edge, 400 mm  
 Reinforced body - 8mm Hardox  
 Automatic body return (only possible with Multitip)  
 Rear lights protection

### Cab:

Extra rotating beacon  
 Air suspended drivers comfort seat  
 Two Electrically adjustable and heated side mirrors  
 DAB-radio with Bluetooth  
 4 ps. Xenon working lights - FRONT  
 2 ps. Xenon working lights - REAR  
 2 ps. Xenon working lights - SIDE  
 4 ps. LED working lights - FRONT  
 2 ps. LED working lights - REAR  
 2 ps. LED working lights - SIDE

### Machine:

Engine heater (220 V)  
 Bio-hydraulic oil  
 Front mounted three point hitch, cat. 2 - incl. electronic-hydraulic direction of oilflow  
 Towing hitch, rear - fork type  
 Automatic, central lubrication system  
 GPS trackunit  
 Special colour





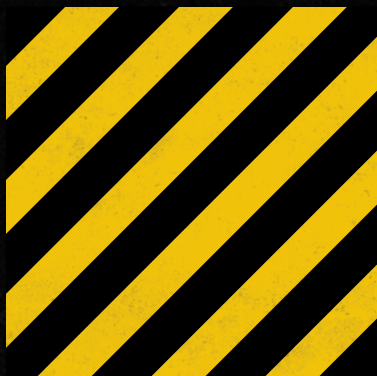

**HYDREMA EXPORT**  
Phone +45 98 37 13 33

**MORE INFO**  
[www.hydrema.com](http://www.hydrema.com)

 **HYDREMA**