



EXD-S 20

EXD 20

EXD-SF 20

EXD Technical data.

High lift pallet trucks for double decker use.



This specification sheet to VDI Guidelines 2198 or 3597 only gives the technical figures for the standard truck.
Different tyres, other masts, additional equipment etc. could give different figure.

				STILL	STILL	
Characteristics	1.1	Manufacturer				
	1.2	Manufacturer's model designation		EXD-S with fixed platform and open at the rear	EXD-S with fixed platform and open at the side	
	1.3	Drive: electric, diesel, petrol, LPG, mains electric		Electric	Electric	
	1.4	Operation (hand, pedestrian, stand-on, sit-on, order picker)		Stand-on	Stand-on	
	1.5	Capacity/load	Q	kg	2000 ¹	2000 ¹
	1.6	Load centre	c	mm	600	600
	1.8	Load distance	x	mm	942	942
	1.9	Wheel base	y	mm	1729	1729
	Weights	2.1	Truck weight (inc. battery)		kg	1500
2.2		Axle load laden	drive end/load end	kg	1550/1950	
2.3		Axle load unladen	drive end/load end	kg	1150/350	
Wheels, chassis	3.1	Tyres			Polyurethan	
	3.2	Tyre size	drive end	mm	ø 250 x 100	
	3.3	Tyre size	load end	mm	ø 85 x 61,5	
	3.4	Swivel castor	drive end		2*ø 140 x 54	
	3.5	No. of wheels (x = driven)	drive end/load end		1x- 2/4	
	3.6	Track width (vorn)	drive end	b ₁₀	mm	470
	3.7	Track width (hinten)	load end	b ₁₁	mm	380
Dimensions	4.2	Height, mast retracted		h ₁	mm	1355
	4.3	Free lift		h ₂	mm	150
	4.4	Lift		h ₃	mm	1580
	4.5	Height, mast extended		h ₄	mm	2070
	4.8	Initial lift		h ₅	mm	130
	4.9	Height of tiller in driving position	min./max.	h ₁₄	mm	1245
	4.15	Height lowered		h ₁₃	mm	91
	4.19	Overall length		l ₁ /l ₁	mm	2568
	4.20	Length including fork backs		l ₂ /l ₂	mm	1418
	4.21	Overall width		b ₁	mm	720
	4.22	Fork dimensions		s/e/l	mm	52/180/1150
	4.24	Fork carriage width		b ₃	mm	711
	4.25	Overall fork width		b ₅	mm	560
	4.31	Floor clearance under mast, laden		m ₁		21
	4.32	Floor clearance, centre of wheel-base		m ₂	mm	25
4.34	Working aisle width with e 800 x 1200 pallet lengthways (b ₁₂ x l ₆)		A _{st} /A _{st}	mm	2768	
4.35	Turning radius		W _a /W _a	mm	2362	
Performance	5.1	Travel speed	laden/unladen	km/h	8/11	
	5.2	Hoist time (Initial lift)	laden/unladen	s	2.0/1.8	
	5.21	Hoist speed (Main lift)	laden/unladen	m/s	0.15/0.23	
	5.3	Lowering time (Initial lift)	laden/unladen	s	1.6/1.6	
	5.31	Lowering speed (Main lift)	laden/unladen	m/s	0.23/0.28	
	5.7	max. Gradeability	laden/unladen	%	7/15	
	5.9	Acceleration time (over 10 m)	laden/unladen	s	7/5	
	5.10	Service brake			electromagnetic	
	Electric motors	6.1	Drive motor, rating S2 = 60 min		kW	3
		6.2	Hoist motor, rating at S3 = 15%		kW	2.2kW S3.5
6.3		Battery to IEC 254-2; A, B, C No			IEC 254-2 ; B	
6.4		Battery voltage, rated capacity C ₅		V/Ah	24V/450	
6.5		Battery weight ± 5% (depends on make)		kg	410	
6.6		Energy consumption to VDI cycle		kWh/h	< 1,2	
Other	8.1	Type of drive control			Pulse control	
	8.4	Sound level at driver's ear		dB (A)	< 70	

¹ Capacity: Initial lift = 2000 kg, double deck use = twice 1000 kg, i.e. 2000 kg total lift



EXD-S: Rear entry

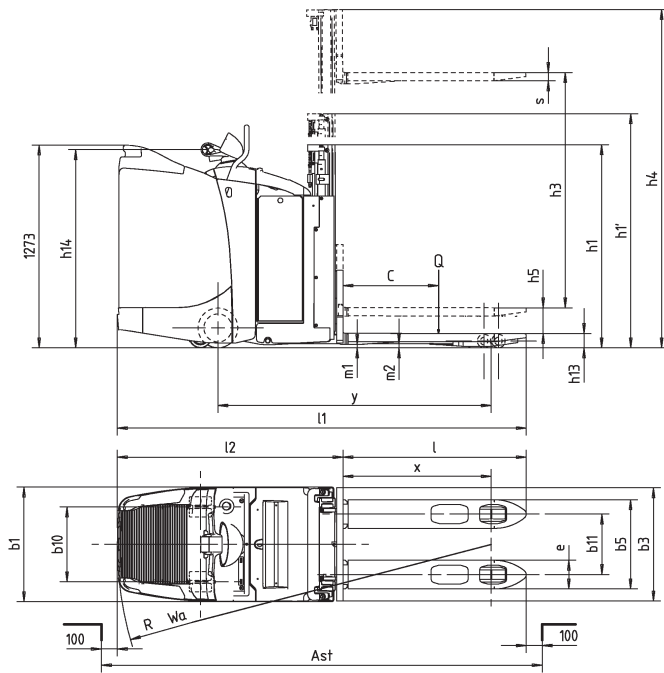

Hydraulics.

- A compact 2.2 kW motor with an integral oil tank, solenoid valves and pressure regulating valves operates the lift cylinder which is fitted with lift cut-out.
- This powerful hydraulic system gives very short lift times and guarantees a high turnaround of goods when loading and unloading lorries, even under maximum load.

Mast and initial lift.

- Optimal view when loading due to the new mast concept.
- Wider mast and improved mast shape allow an optimal view of the load.
- Capacity of the initial lift max. 2,000 kgs. for double loading twice 1,000 kgs.

Brakes.

- The brake system comprises two independent brake circuits.
- „Soft” braking with energy recovery, activated by releasing the drive switch or plugging
- Emergency braking by the push-button in the COCKPIT.
- Driving is only possible when the operator is stood on the platform. The platform acts as a dead man switch

Battery.

- The battery is easily accessible, and for multi- shift operation can be changed from the side with an integral roller track.
- Two battery trays for 450 Ah or 600 Ah batteries.

Options.

- Unique modular accessory system thanks to multi-functional frame over the battery cover
- Adjustable A 4 writing surface with paper clip
- Prepared for data terminal
- Additional mounting system for further accessories (on request).
- Cold store version (-30 °C)
- Battery tray for 600 Ah-battery.
- Extended access control and Fleet Management with STILL Fleetmanager

Safety.

- The trucks comply with the EC Guidelines 98/37 and carry the CE symbol.
- Still is certified to ISO 9001
- Speed reduction at a higher loading thanks to OPTISPEED.

EXD-S: Side entry

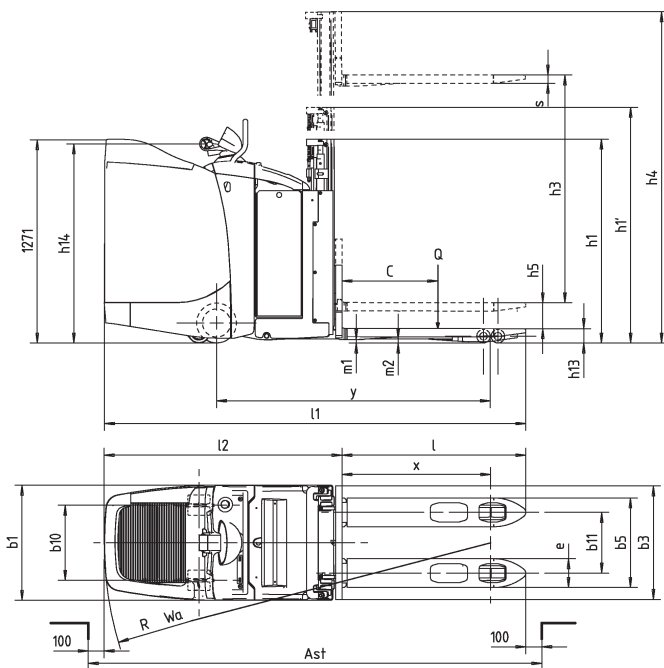

The EXD-S is a heavy-duty double decker high lift pallet truck that can lift a maximum of 2,000 kgs when using the initial lift or twice 1,000 kgs when utilising double decker loading and unloading. Two pallets can be transported simultaneously with the EXD-S - so time can be saved by the efficient loading and unloading of lorries.

Frame.

- The frame design has been specially developed for use in lorries and tight spaces. The contour of the edges is particularly helpful when driving over ramps or into lorries.
- The tips and undersides are formed as skids and allow easy access into pallets. The curved corners of the platform make it possible to drive backwards out of the lorry even for the last two rows of pallets, without bumping into the tailgate or the rubber seal on the ramp.
- The platform is permanently welded to the frame forming a very stable, D-shaped box section, which can cope with even the most arduous ramp applications.
- To ensure optimal traction all the time, the central drive wheel has a sprung suspension and exerts a wheel pressure that increases proportional to the load on the forks.
- Lateral stability is ensured by two well-engineered large twin support wheels, specially developed for the EXD-S and the typical Heavy Duty applications.

Steering.

- Fully electronic "fly by wire" steering with automatic neutral position.
- When driving straight ahead any unintentional steering movements are filtered out electronically, in order to achieve a precise, straight run.
- Automatic speed reduction when cornering and side support wheels give the truck a high stability on curves and reduce the centrifugal forces in the bend.

Multifunction control.

- The new "COCKPIT" multifunction control contains all steering, driving and monitoring functions for the EXD-S.
- Thanks to the ergonomic arrangement of the switches, all functions can be reached by the driver without changing his grip.
- The following functions are housed in the COCKPIT:
 - Driving
 - Steering
 - Lifting and lowering: Lift and initial lift
 - Work hour meter
 - Battery indicator
 - Adjustable driving profiles
 - Access control (With Code master switches as standard)
 - Diagnostics (through Service code)
 - More secure support when driving

Driver's platform.

- Depending on the application the EXD-S is available with two different platform versions, both of which are matched to the particular ergonomic requirements of the operator. Applications and requirements vary so greatly that they cannot be covered with a single platform.
- For the horizontal movement of goods over long distances, the operator remains on the platform for almost the whole of the time. Here the platform with side entry offers the greatest comfort and safety for both directions of travel.
- When the operator has to step in and out frequently for secondary activities (scanning, order picking.) this is best done with a platform with an entry at the rear.
- Thanks to the padded backrest and the ergonomically shaped side support, both platforms offer a high level of comfort, particularly also due to the sprung mounting, which in this form is unique on the market and protects the operators back.
- The driver's compartment offers various storage facilities and a roll storage area.
- A writing surface with paper clip is provided as standard on the EXD-S.

Drive.

- Powerful, economical and hence cost saving, thanks to a 3.0 KW AC motor.
- With two selectable drive programmes the operator can match the drive characteristics to the application or to his personal preference.
- In the "ECO" mode (Tortoise button), the motor runs at its standard speed drawing less current and accelerates more gently which means an extra 15% longer per battery charge compared to a standard model.
- In the "BOOST" mode (Hare button) the motor runs at maximum speed to achieve maximum productivity. In this mode the operating period does not change, but the productivity increases by 25% in comparison to other models.
- In both modes the driving profile can be matched precisely to the particular requirements of the application and the driver (speed, acceleration, braking).
- A speed sensor, combined with the control unit, ensures smooth acceleration of the EXD-S up to maximum speed regardless of the load on the forks.
- The truck will brake when the drive switch in the COCKPIT is released or the driver brakes. Here the AC motor functions as a generator and stores the energy gained from braking in the battery.
- When stopped on a gradient or if the drive switch is released, the controller monitors each movement of the truck and prevents uncontrolled rolling back by closing the motor brake.

This specification sheet to VDI Guidelines 2198 or 3597 only gives the technical figures for the standard truck.
Different tyres, other masts, additional equipment etc. could give different figures.

Characteristics	1.1	Manufacturer			STILL	STILL			
	1.2	Manufacturer's model designation			EXD 20	EXD-SF 20			
	1.3	Drive: electric, diesel, petrol, LPG, mains electric			Electric	Electric			
	1.4	Controls (hand, pedestrian, stand on, rider seated, order picker.)			Pedestrian	Stand-on/pedestrian			
	1.5	Capacity/load	Q	kg	1000 + 1000	1000 + 1000			
	1.6	Load centre	c	mm	600	600			
	1.8	Load distance	x	mm	1022	1022			
	1.9	Wheel base	y	mm	1518	1518			
	Weights	2.1	Truck weight (inc. battery)		kg	1044	1156	1078	1190
2.2		Axle load laden	drive end/load end	kg	1012/2032	1276/1880	1016/2062	1286/1904	
2.3		Axle load unladen		kg	694/350	814/342	722/356	844/346	
Wheels, chassis	3.1	Tyres (rubber, Vulkollan, pneumatic, polyurethane)			Polyurethan +	Polyurethan +			
	3.2	Tyre size	drive end	mm	ø 230 x 75	ø 230 x 75			
	3.3	Tyre size	load end	mm	2x ø 85 x 80	2x ø 85 x 80			
	3.4	Support castors	drive end	mm	ø 140 x 54	ø 140 x 54			
	3.5	No. of wheels (x = driven)	drive end/load end		1 x -2/4	1 x -2/4			
	3.6	Track width	drive end	b ₁₀	mm	495	495		
	3.7	Track width	load end	b ₁₁	mm	380	380		
Dimensions	4.2	Height, mast retracted		h ₁	mm	In the mast table	In the mast table		
	4.3	Free lift		h ₂	mm	In the mast table	In the mast table		
	4.4	Lift		h ₃	mm	In the mast table	In the mast table		
	4.5	Height, mast extended		h ₄	mm	In the mast table	In the mast table		
	4.6	Basic lift		h ₅	mm	130	130		
	4.9	Height of tiller in driving position	min./max.	h ₁₄	mm	1070/1558	1109/1303		
	4.15	Height lowered		h ₁₃	mm	91	91		
	4.19	Overall length without load		l ₁	mm	2086	2162	2086/2500	2162/2576
	4.20	Length including fork backs		l ₂	mm	936	1012	936/1350	1012/1426
	4.21	Overall width		b ₁	mm	720	720		
	4.22	Fork dimensions		s/e/l	mm	52/180/1150	52/180/1150		
	4.24	Fork carriage width		b ₃	mm	710	710		
	4.25	Overall fork width		b ₅	mm	560	560		
4.32	Floor clearance, centre of wheel-base		m ₂	mm	25	25			
4.34	Working aisle width with 800 x 1200 pallet lengthways (b ₁₂ x l ₆)		A _{st}	mm	2334	2410	2334/2748	2410/2824	
4.35	Turning radius		W _a	mm	1904	1980	1904/2318	1980/2394	
Performance	5.1	Travel speed	laden/unladen	km/h	6.0/6.0	7.5/9.0			
	5.2	Hoist speed	laden/unladen	m/s	2.6/2.2	2.6/2.2			
	5.21	Hoist speed (Initial lift)	laden/unladen	m/s	0.16/0.31	0.16/0.31			
	5.3	Lowering speed	laden/unladen	m/s	2.2/2.2	2.2/2.2			
	5.31	Lowering speed (Initial lift)	laden/unladen	m/s	0.3/0.25	0.3/0.25			
	5.7	Gradeability	laden/unladen	%	7/15	7/15			
	5.9	Acceleration time (over 10 m)	laden/unladen	s	8/7	7.2/5.85			
5.10	Service brake				electromagnetic	electromagnetic			
Electric motor	6.1	Drive motor, rating S2 = 60 min		kW	2.3	2.3			
	6.2	Hoist motor, rating at S3		kW	2.2/7%	2.2/10%			
	6.3	Battery to DIN 43531/35/36; A, B, C, No			2PzS	3PzS	2PzS	3PzS	
	6.4	Battery tvoltage, rated capacity C ₅		V/Ah	24 V/240 Ah	24 V/360 Ah	24 V/240 Ah	24 V/360 Ah	
	6.5	Battery weight ± 5% (depends on make)		kg	220	290	220	290	
	6.6	Energy consumption to VDI cycle		kWh/h	0.75	1.07			
Other	8.1	Type of drive control			AC controller	AC controller			
	8.4	Sound level at driver's ear		dB (A)	66	66			

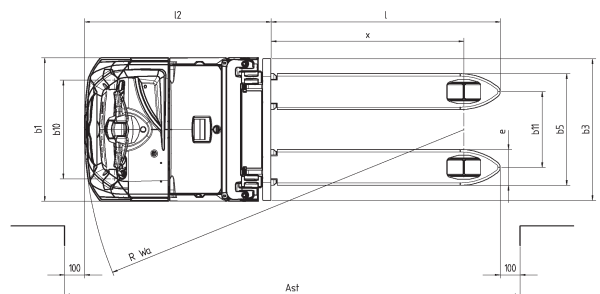
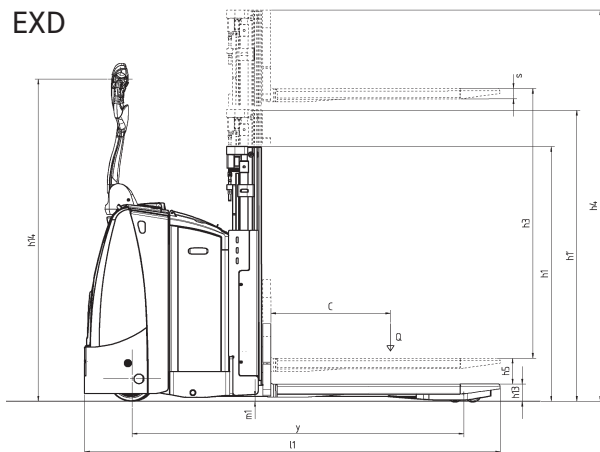
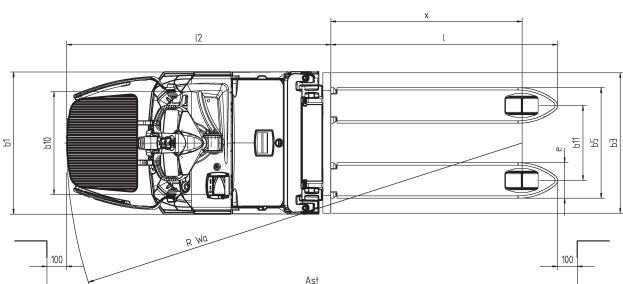
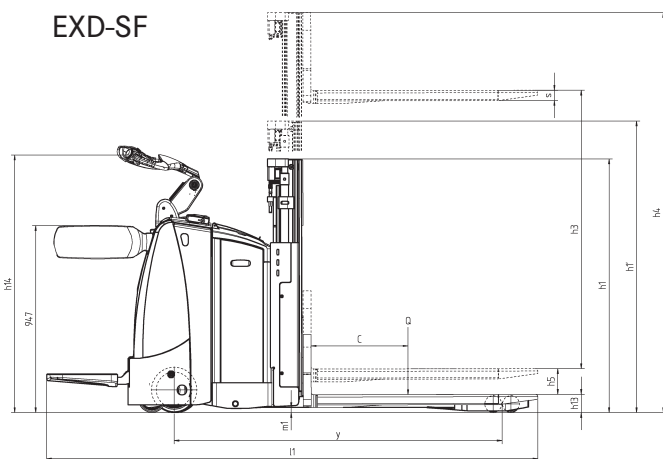

	DX		Ni-Ho	
h ₃	1580	2024	2424	2924
h ₁	1355	1600	1800	1975
h ₂	150	150	150	1462
h ₄	2070	2537	2937	3437

EXD**EXD-SF****Hydraulics.**

- A compact 2.2 kW motor with an integral oil tank, solenoid valves and a pressure regulating valve provide smooth movement of the lift cylinder which is fitted with lift cut-out.
- This powerful hydraulic system gives quick lift times and guarantees a high turnaround of goods when loading and unloading lorries, even under maximum load.

Mast and Initial lift.

- A wider mast and the improved mast shape allow an optimal view of the load.
- The pulse controller provides the facility to position the forks precisely at the desired level.
- Fully proportional hydraulics are achieved by electronic control of the pump motor speed.
- The capacity of the initial lift is a maximum of 2,000 kgs maximum, or for double loading twice 1,000 kgs.

Brakes.

- The EXD and EXD-SF provide double security due to two independent brake circuits:
- The smooth generator service brake, which is activated by releasing or reversing the butterfly switch.
- The electromagnetic emergency disc brake, which is activated by the Emergency Off button or putting the tiller into the vertical position.
- On the EXD-SF driving is only possible when the operator is standing on the platform which acts as a dead man switch. Pedestrian operation is only possible when platform and side guard are folded in (EXD-SF).

Battery.

- The battery is easily accessible and can thus easily be charged, serviced and topped up. In a multi-shift operation the battery can be changed vertically with a hoist or as an option from the side.
- Two battery trays are available for 250 Ah or 375 Ah batteries.
- The metal battery cover is completely within the contours of the EXD und EXD-SF truck and is thus protected against collisions.

Options.

- Modular accessory system exclusively from STILL
- Adjustable A 4 writing surface with paper clip.
- Combi-tiller
- Drive wheels in different materials (Polyurethane, Solid rubber, Non-marking ...).
- Prepared for data terminal
- Load backrest - 800 mm high
- Cold store version (-30 °)
- Access control and Fleet Management with STILL FleetManager.
- Accident recorder (optional in conjunction with STILL FleetManager).
- Battery cover with stretch film holder.

Safety.

- STILL forklift trucks are built to the EC guideline 98/37 and are marked with the CE symbol.
- Still is certified to ISO 9001.
- Speed reduction at a higher loading thanks to OPTISPEED.

EXD/EXD-SF Technical data.

Double decker high lift pallet truck.

The EXD and EXD-SF are double decker high lift pallet trucks which can lift a maximum of 2,000 kgs when using the initial lift or twice 1,000 kgs when using double deck loading and unloading. Two pallets can be transported simultaneously with the EXD and EXD-SF so time can be saved by the efficient loading and unloading of lorries. Whilst the sprung hinged platform (optional on the EXD, standard on the EXD-SF) in conjunction with the very compact build allows manoeuvring in even the tightest space, the adjustable height side guards (not fitted on the EXD) provide a high degree of individual support for the operator. With two drive programs for maximum battery usage time or maximum productivity, the operator can prepare himself for any task. The electrical tiller steering with speed reduction when cornering proportional to the steering angle gives the EXD and EXD-SF a high degree of safety in use. The best driving characteristics and high stability, thanks to a sprung drive wheel and fixed support castors round off the profile of the EXD-SF.

Frame.

- Particularly compact dimensions and flowing lines assist the manoeuvrability of EXD-SF which is important in the loading and unloading of lorries.
- To ensure manoeuvrability in the tightest spaces, for example when loading and unloading the first pallets, when the truck is parked in a goods lift or has to be transported directly in a lorry for delivery journeys, the driver's platform and side guard fold up.
- The sprung central drive unit exerts a constant wheel pressure proportional to the load on the forks thus ensuring excellent traction when accelerating and braking.
- Two robust support wheels ensure outstanding lateral stability.

Steering.

- The EXD and EXD-SF are fitted as standard with particularly precise and user-friendly power steering.
- In the central tiller position any unintentional steering movements are filtered out electronically, in order to ensure precise straight ahead running.
- Paired with side support wheels the automatic speed reduction when cornering gives great stability and reduces the effects of centrifugal force on the operator and the load.

Tiller.

- All "SF" trucks are fitted with a stand-on platform for the driver. The dampening element is newly developed and allows to adjust the suspension individually to the weight of the driver.
- The switches are ergonomically designed to be suitable for right or left handed operators. The push button for the horn and also the lifting and lowering function can be operated with one hand without changing the grip. Well thought out details for untiring work!
- Thanks to the large sized buttons with a combination of indentations and projections any function can be felt even with industrial gloves, without the operator having to see the buttons.
- The layout of the controls allows simultaneous operation of the various functions, e.g. lifting and driving.
- The design of the switch elements (micro switches) and tiller PCB is to Enclosure Class IP 65, all plug connectors and also cable harnesses to IP 54, so there is little susceptibility to environmental factors such as rain or dust.
- Extremely robust tiller head in glass fibre reinforced polyurethane.

Driver's station.

- The prevention of muscular problems by good ergonomics and special equipment is a priority at STILL.
- The EXD-SF is fitted as standard with a hydraulically damped driver's stand-on platform. This system, unique in warehouse handling equipment, absorbs the impacts and vibrations transmitted from the floor, especially over expansion joint and dock levellers.
- The suspension is easy to regulate through a valve and offers the driver the chance to choose his personal comfort setting. A table with guideline figures based on the driver's weight gives an initial guide here.
- The wide hinged side guards are made of forged steel for maximum protection
- Here too STILL has considered the ergonomics of the driver's station and offers a unique, patented system for adjusting the height of the protective side guards. Now operators of all sizes can find their ideal position on the platform of the EXD-SF, regardless of what position is comfortable for them.
- When not in use the rider platform and side guards fold up within the contours of the truck which means less potential damage and increased manoeuvrability.

Drive.

- Powerful, economical three phase technology with a drive power of 2.3 kW.
- With two selectable drive programmes the operator can match the drive characteristics to the application or to his personal preference.
- In the „ECO“ mode (Tortoise button), the motor accelerates more gently and thus achieves a greater battery range with consistently high productivity.
- In the „BOOST“ mode (Hare button), the motor runs at maximum speed to achieve maximum productivity. When extra power is needed, for example at the end of a shift, this is an extra benefit.
- Due to the proportionality and precise monitoring of the torque the EXD-SF always runs smoothly.
- The travel speeds can be co-ordinated to the operator's requirements.
- When stopped on a gradient or a slope and also if the drive switch is released, the controller monitors each rolling movement of the truck and prevents uncontrolled rolling back by closing the motor brake.



Your contact

STILL GmbH
Berzeliusstraße 10
D-22113 Hamburg
Telephone: +49 (0)40/73 39-2000
Telefax: +49 (0)40/73 39-2001
info@still.de

For further information please visit:
www.still.de

STILL Materials Handling Ltd.
Aston Way, Leyland
Lancashire PR26 7UX
Telephone: +44 (0)1772 644300
Telefax: +44 (0)1772 644303
info@still.co.uk

For further information please visit:
www.still.co.uk