

# MODEL RANGE

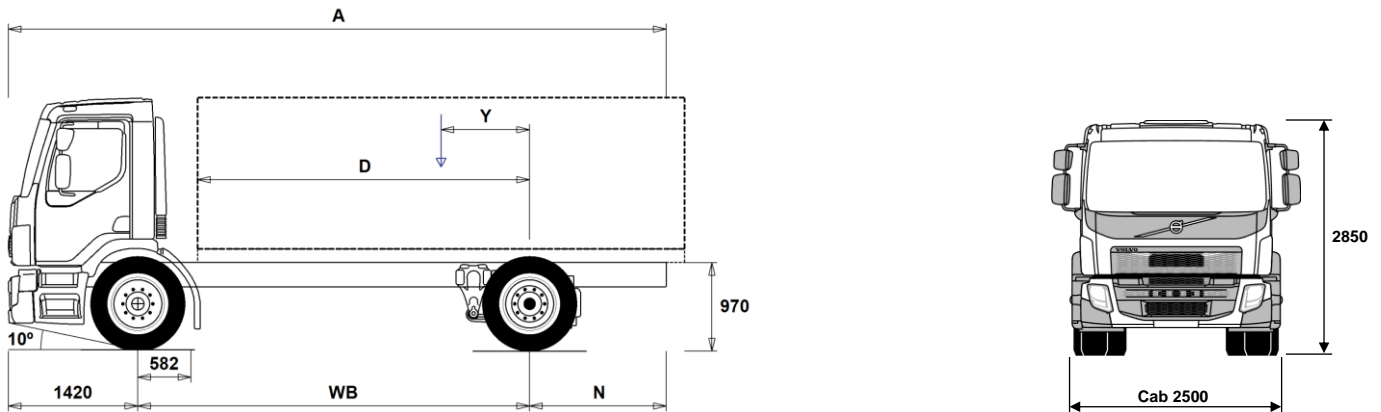

Volvo Trucks. Driving Progress

## FE818 4x2 Platform 18 tonne - Rear Air Suspension FE 42 R A



### Chassis Dimensions [mm]

WB Wheelbase	3500	3700	3900	4100	4300	4500	4750	5000	5250	5500	5800	6100	6450	6800
A Overall Chassis Length	6610	6910	7260	7560	7910	8210	8610	9010	9410	9810	10310	10760	11310	11560
D Center of rear axle to front of body	2844	3044	3244	3444	3644	3844	4094	4344	4594	4844	5144	5444	5794	6144
N Rear Overhang (Min.)	640	640	640	640	640	640	640	2590	2740	2890	3090	3240	3440	3340
N Rear Overhang (Max.)	1690	1790	1940	2040	2190	2290	2440	2590	2740	2890	3090	3240	3440	3340
Y Center of Gravity for Payload (Min.)	726	769	814	855	898	942	996	1049	1104	1157	1221	1283	1359	1427
Y Center of Gravity for Payload (Max.)	895	948	1002	1054	1108	1161	1228	1294	1361	1428	1507	1585	1679	1765

### Chassis Weights [kg]

Front Axle	3920	3915	3910	3925	3925	3920	3920	3930	3925	3930	3940	3955	3955	3965
Rear Axle	1645	1660	1685	1725	1745	1765	1785	1815	1835	1855	1900	1935	1955	1965
Kerb Weight	5565	5575	5595	5650	5670	5685	5705	5745	5760	5785	5840	5890	5910	5930
Payload (including body, driver, fuel, etc.)	12435	12425	12405	12350	12330	12315	12295	12255	12240	12215	12160	12110	12090	12070

### Turning Diameter [mm]

Turning Circle Diameter Kerb to Kerb	12800	13400	14100	14700	15300	15900	16700	17400	18200	19000	19900	20800	21900	23000
Turning Circle Diameter Wall to Wall	14200	14900	15500	16100	16700	17300	18100	18900	19600	20400	21300	22300	23300	24400

### Plated Weights [kg]

	Plated	Design
Gross Vehicle Weight	18000	18000
Gross Combination Weight	24000	24000
Front Axle	7100	7100
Rear Axle	11500	13000

### Important Notes

#### Chassis Dimensions

Front Axle to Back of Cab: +358 mm for CAB-SLP, +196 mm for CAB-SSLP.

D-measure includes a front clearance of 74 mm and for rigid trucks also a subframe of 120 mm.

Height can vary  $\pm 20$  mm for leaf and  $\pm 10$  mm for air suspension.

All dimensions are for unladen chassis and any tag axles down. Chassis height used: CHH-MED.

Height change when chassis height CHH-HIGH,FRAME300: +17 mm.

Weight and dimensions are based upon the following tyres:

Front Axle Tyres: 295/80R22.5

Drive Axle Tyres: 295/80R22.5

Chassis weight includes oil, water, AdBlue, 0 litres fuel and without driver. Kerb weight can vary  $\pm 3\%$ .

Turning diameters are theoretically calculated.

Legal weights can differ from country to country.

For more detailed weight information, including optional equipment weights, ask your Volvo sales contact to enter your specification into the Volvo Weight Information system (WIS).

Do NOT use this drawing for bodybuilding. Refer to Volvo Bodybuilder Instructions and chassis assembly drawing FE42RA.

# MODEL RANGE

## FE818 4x2 Platform 18 tonne - Rear Air Suspension FE 42 R A

### TRUCK USE

- **TGW-4G** GSM/GPRS/4G modem, WLAN for telematics gateway
- **FELECD** Volvo FE Low entry cab 2 person with engine tunnel diesel
- **FELECFDD** Volvo FE Low entry cab 4 person crewcab diesel
- **RC-ROUGH** Operating class on/off road
- **RC-SMOOT** Operating class highway
- **GARB-PRE** Garbage preparation
- **TIPP-PRE** Tipper vehicle preparation
- **UNIFORM** Basic platform vehicle

### CORE COMPONENTS

- **CHH-HIGH** Chassis height high - N3 "On Road" chassis - For a specific loading height always check the unique BEP chassis drawing
- **CHH-LOW** Chassis height low - For a specific loading height always check the unique BEP chassis drawing
- **CHH-MED** Chassis height medium - For a specific loading height always check the unique BEP chassis drawing
- **RAD-KR** Two bag rear air suspension
- **EU6SCR** Emission level - Euro 6
- **D8K250** D8K250 six cylinder 7.7 litre engine developing 250hp at 2100rpm.  
Peak torque 950Nm at 900-1700rpm.
- **D8K280** D8K280 six cylinder 7.7 litre engine developing 280hp at 2100rpm.  
Peak torque 1050Nm at 950-1700rpm.
- **D8K320** D8K320 six cylinder 7.7 litre engine developing 320hp at 2100rpm.  
Peak torque 1200Nm at 1050-1600rpm.
- **D8K350** D8K350 six cylinder 7.7 litre engine developing 350hp at 2100rpm.  
Peak torque 1400Nm at 1200-1600rpm.
- **EBR-CEB** Exhaust brake producing 170kW at 2800rpm controlled by steering column switch
- **EBR-EPG** Exhaust brake producing 120kW at 2800rpm controlled by steering column switch
- **AL306** Allison AL306 6-speed automatic gearbox (If a PTO is required it must specified from the factory)
- **AT2412F** AT2412F 12-speed "I-shift" automated mechanical gearbox suitable for gross train weights up to 44tonne only refer to sales engineering when used in conjunction with a PTO
- **ZTO1006** 6-speed overdrive gearbox
- **ZTO1109** 9-speed range change overdrive gearbox
- **RSH1370F**
- **RSS1344C** RS1344C single reduction rear axle - design GCW 44tonne with differential lock
- **RSS1344D** RS1344C single reduction rear axle - design GCW 44tonne with differential lock
- **RSS1344E** RSS1344E single reduction rear axle with differential lock - design GCW 44tonne

### Packages

- **DRIVEFE** NEW drive package FE
- **VISIFE** NEW visibility package FE
- **AIRFLOW** NEW airflow package
- **FUELFE** NEW Fuel package FE
- **AUDIODAB**
- **AUDIOPD**

### CHASSIS

- **FST-AIR** Front suspension type, air
- **FST-PAR** Parabolic front springs
- **FAL7.1** Front axle design capacity 7.1 tonnes
- **FAL7.5** Front axle design capacity 7.5 tonnes
- **FAL8.0** Front axle design capacity 8.0 tonnes - Ensure that you have checked the tyre load index
- **FAL9.0** Front axle design capacity 9.0 tonnes - Ensure that you have

- Standard Equipment
- Optional Equipment

For more detailed information about cab and powertrain equipment, please refer to separate specification sheets.

For all possible options and combinations of options please consult your Volvo sales contact who can create a specification to match your requirements using the Volvo Sales Support system (VSS).

The factory reserves the right to modify design and change equipment without previous notification. The specification can vary from country to country.

- **RAL13** checked the tyre load index
- **RSTAB1** Rear axle design capacity 13 tonnes
- **EBS-MED** Rear anti-roll bar
- **EBS-STD** EBS+ package including traction control & hill hold
- **RST-AIR** EBS standard package without traction control
- **RST-AIR5** Rear air suspension
- **ABS** Anti lock brakes
- **SUSPL-E2** Integral dash switches for air suspension leveling control
- **SUSPL-E4** Integral dash switches for air suspension leveling control
- **FRAME266** Frame rail section external height 266 mm
- **FRAME300** Frame rail section external height 300 mm
- **FST7070** Frame thickness 7mm
- **FST8080** Frame thickness 8mm
- **2BATT170** 2 x 170 Ah capacity batteries on left hand side
- **2BATT225** 2 x 225 Ah capacity batteries on left hand side
- **ADR2** ADR package for transportation of dangerous goods on road (Note does NOT include safe loading pass package if required this is quoted separately)
- **R255A56** 255 litre right hand aluminium 560 mm D-shaped fuel tank  
Min volume 160l  
Max volume 630l
- **UL-FUEL** Without left fuel tank  
Min volume 160l  
Max volume 315l
- **ADTP-L** AdBlue tank on left hand side
- **ADTP-R** AdBlue tank on right hand side
- **WHC-FIX1** One wheel chock
- **WHC-FIX2** Two wheel chocks
- **TB-L33** Toolbox 330 x 330 mm on the left side
- **TB-L75** Toolbox 754 mm on the left side
- **TOWMBRH** Towing member, high position, mounted in centre of frame
- **RFEC-S** Rear frame end, straight cut for platform applications
- **C-RI4040** Towing coupling, Ringfeder 4040 G-150
- **C-RI5055** Towing coupling, Ringfeder 5055 G-150
- **C-RO400G** Towing coupling, Rockinger 400 G-150 for 40mm eyes
- **C-RO40AG** Towing coupling, Rockinger 400 G-145
- **C-RO430G** Towing coupling, Rockinger 430 G-150
- **C-RO43AG** Towing coupling, Rockinger 430 G-145
- **C-RO50** Rockinger RO 50 50mm for centre axle trailer
- **TOWR-ONE** Towing hitch attached to rear crossmember
- **TBC-EC** Palm coupling type air line connectors
- **TRBR-STA** Stationary trailer brake control
- **RUP-FIX2** Fixed rear EC approved aluminium underrun
- **RFEND-B** Three piece rear mudwings
- **RFEND-T** Mudwings on drive axle for transportation only
- **RFH-103** Quarter rear wing
- **RFH-BAS** Basic rear wing height
- **RFH-HIG** High rear wing height - higher wing tops
- **RFH-LOW** Lower rear wing height - shallower wing tops
- **ATANK-AL** Aluminium air tanks
- **ATANK-ST** Steel air tanks
- **FRACLOS** With frame closing

### WHEELS & TYRES

- **RT-AL** Alcoa brushed aluminium rims with standard holes for long stud fixing on all axles
- **RT-ALDP** Alcoa Dura-Bright aluminium rims with standard holes long stud fixing on all axles, requires cleaning with a ph neutral solution - washing up liquid.

# MODEL RANGE

## FE818 4x2 Platform 18 tonne - Rear Air Suspension FE 42 R A

- **RT-ALP** Polished aluminium rims with standard holes (long stud fixing) on all axles
  - **RT-STEEL** Steel rims on all axles
  - **SPWT-F** Spare wheel & tyre with front tyre pattern
  - **SWCP-R** Spare wheel carrier rear mounted below frame.
  - **SWCP-T** Spare wheel supplied temporarily strapped to chassis
  - **SWCP-TP** Spare wheel transport mounted on frame, (spare wheel carrier not included)
- ### DRIVELINE EQUIPMENT
- **TP-BAS** I-shift software - basic
  - **TP-DICON** I-shift software - Distribution and Construction
  - **TP-FUEC** I-shift software - Fuel & economy
  - **APF-ENH** I-shift enhanced PTO functions
  - **APF-ENH2** I-shift enhanced PTO functions on service brake
  - **CS39A-O** Single plate 395mm (16") clutch
  - **CS43B-O** Single plate 430mm (17") clutch
  - **RET-TPT** Retarder for automatic gearbox
  - **TC-HWO** Automatic gearbox oil cooler - water to oil
  - **TC-MWO** Basic transmission oil cooler - water to oil
  - **AIRIN-HI** High air intake behind cab on left hand side
  - **AIRIN-RL** Chassis mounted mounted behind cab on right hand side
  - **ACL1ST-S** Air filter with secondary filter element
  - **24AL110B** 110 amp alternator
  - **CCV-C** Closed crankcase ventilation
  - **CCV-OX** Open crankcase ventilation with oil separator and a maintenance free gas centrifuge
  - **AF-E** Auxiliary fuel filter, electrically heated
  - **EST-AID** Engine start preheating element
  - **220EBH08** Engine block heater, 220V/0.8kW
  - **PTER-100** Rear engine mounted power-take-off with DIN 7476 flange
  - **PTER-DIN** Rear engine mounted PTO with DIN5462 (female) splined shaft for a close coupled pump
  - **PTER1400** Rear engine mounted power-take-off with SAE 1410 flange
  - **PR-HP4T** Live-drive PTO for Allison gearbox output 400Nm for hydraulic pump connection mounted on top of the torque convertor
  - **PR-HP4TL** Live-drive low speed PTO for Allison gearbox output 400Nm for hydraulic pump connection mounted on top of the torque convertor
  - **PR-HP6TH** Live-drive high speed PTO for Allison gearbox output 600Nm for hydraulic pump connection mounted on top of the torque convertor
  - **PR-HP6TL** Live-drive low speed PTO for Allison gearbox output 600Nm for hydraulic pump connection mounted on top of the torque convertor
  - **PTR-FH1** Rear PTO Gearbox S81 flange DIN connection
  - **PTR-FH2** Rear PTO Gearbox S84 flange DIN connection
  - **PTR-FH5** Rear PTO Gearbox S88 flange DIN connection
  - **PTR-PH1** Rear PTO Gearbox S81 pump DIN connection
  - **PTR-PH2** Rear PTO Gearbox S84 pump DIN connection
  - **PTR-PH4** Rear PTO Gearbox S88 pump DIN connection
  - **PTR-PK** Electrical and solenoid prep kit for gearbox PTO
  - **PTR-ZF2** Rear Power Take Off flange DIN connection
  - **PTR-ZF4** Rear PTO Gearbox 320Nm flange connection
  - **PTR-ZF5** Rear PTO Gearbox 320Nm pump connection
  - **PTRD-D1D** PTO for I shift with twin outputs - flange (550 Nm) and pump connection (1000 Nm)
  - **PTRA-PH1** Add PTO for 9sp box twin S81 pump conn
  - **PTRA-PH2** Add PTO for 9sp box twin S84 pump conn
  - **HPG-F101** Gearbox mounted hydraulic pump F1-101, fixed displacement, single flow.
  - **HPG-F41** Gearbox mounted hydraulic pump F1-41, fixed displacement, single flow.
  - **HPG-F51** Gearbox mounted hydraulic pump F1-51, fixed displacement, single flow.
  - **HPG-F61** Gearbox mounted hydraulic pump F1-61, fixed displacement, single flow.
  - **HPG-F81** Gearbox mounted hydraulic pump F1-81, fixed displacement, single flow.
  - **ETC** Electronic throttle control - dash mounted switch for PTO speed control
  - **FLAMEPR** Flame protection in the exhaust system
- ### CAB INTERIOR
- **STWPOS-L** LEFT HAND DRIVE
  - **STWPOS-R** RIGHT HAND DRIVE
  - **IMMOBIL** Immobiliser
  - **WARNLAMP** Portable warning lamp
  - **ALARM-B** Vehicle alarm - cab only
  - **WARNVEST** High visibility warning vest - no sleeves
  - **AIDKIT** First aid kit - Legal demand for EU markets including delivery to EU bodybuilder
  - **AIDKIT1B**
  - **CRUIS-E2** Cruise control for I shift Eco Roll
  - **CRUISEC** Cruise control with switches in the steering wheel
- ### CAB EXTERIOR
- **AUXFS** Extra foot step on both sides
  - **CF-AFS** Foldable extra front cab foot-step
  - **RCABS-A** Rear cab suspension - Air
  - **RCABS-M** Rear cab suspension - Mechanical spring
  - **AD-ROOF** Fixed cab roof air deflector - not adjustable
  - **AD-ROOFA** Adjustable roof deflector with 12 positions
  - **AD-SIDES** Cab side air deflector, short extension panels.
  - **HL-CLEAN** Head lamp cleaner jet
  - **HL-ADJ** Adjustable headlights with switch in the cab
  - **DRL-LED** V-shaped day time running lights
  - **BEACON-P** Beacon preparation
  - **BEACONA2** Two amber beacons directly mounted to cab roof
  - **HORN-F1S** Single tone air horn chassis mounted
  - **HORN-R2S** Two roof mounted air horns
- ### SUPERSTRUCTURE PREPARATIONS
- **FBA-BTF** Lower front body attachments for torsionally flexible - platform body
  - **FBA-BTS** Pre-punched front body attachment holes for torsionally stiff body - tanker
  - **FBA-BTSF** Lower front body attachments for torsionally semi-flexible body - box or curtainsider
  - **RBA-T1** Rear body attachments, plates
  - **RBA-T2** Rear body attachments, divided
  - **HBA-FSFB** Holes for body attachments - flexible/semi-flexible body
  - **HBA-SB** Holes for body attachments - stiff body
  - **TAILPREP** Taillift preparation kit - cab switch and warning in driver display
- ### DELIVERY SERVICES
- **WVTA** Whole Vehicle Type Approved - MANDATORY for standard truck

# VOLVO

Volvo Truck Corporation

volvotrucks.com