



FORTENS™

STRONG PARTNERS. TOUGH TRUCKS.



IC Counterbalanced Lift Trucks
H4.0-5.5FT Fortens / Fortens Advance / Fortens Advance+

4 000 – 5 500 kg

Fortens H4.0FT, H4.5FT, H5.0FT, H5.5FT

CHARACTERISTICS	1.1	Manufacturer	
	1.2	Model designation	
		Model - Manufacturer designation	
		Engine/Transmission	
		Brake Type	
	1.3	Power: battery, diesel, LPG, electric mains	
	1.4	Operation: manual, pedestrian, stand, seat, orderpicker	
	1.5	Load capacity	Q (kg)
	1.6	Load centre	c (mm)
1.8	Load distance	x (mm)	
1.9	Wheelbase	y (mm)	

H4.0FT5	H4.0FT5	H4.0FT6	H4.0FT6	H4.5FTS5
Fortens	Fortens	Fortens	Fortens	Fortens
Kubota 3.6L	Kubota 3.6L	Kubota 3.6L	Kubota 3.6L	Kubota 3.6L
Basic Powershift	Basic Powershift	Basic Powershift	Basic Powershift	Basic Powershift
1-speed	2-speed	1-speed	2-speed	1-speed
ADS Drum	ADS Drum	ADS Drum	ADS Drum	ADS Drum
Diesel	Diesel	Diesel	Diesel	Diesel
Seat	Seat	Seat	Seat	Seat
4 000	4 000	4 000	4 000	4 500
500	500	600	600	500
522,1	522,1	522,1	522,1	522,1
1 830	1 830	1 830	1 830	1 830

WEIGHTS	2.1	Unladen weight	kg
	2.2	Axle loading with load, front/rear	kg
	2.3	Axle loading without load, front/rear	kg

6 298	6 298	6 672	6 672	6 630					
8 849	1 077	8 849	1 077	8 910	1 390	8 910	1 390	9 496	1 216
2 923	3 375	2 923	3 375	3 003	3 669	3 003	3 669	2 829	3 801

WHEELS & TYRES	3.1	Tyres: L=pneumatic, V=solid, SE=pneumatic-shaped solid	
	3.2	Tyre size, front	
	3.3	Tyre size, rear	
	3.5	Number of wheels, front/rear (X = driven)	
	3.6	Track width, front	b ₁₀ (mm)
	3.7	Track width, rear	b ₁₁ (mm)

SE	SE	SE	SE	SE					
250 x 15	250 x 15	250 x 15	250 x 15	250 x 15					
7,00 x 12	7,00 x 12	7,00 x 12	7,00 x 12	7,00 x 12					
2X	2	2X	2	2X	2	2X	2	2X	2
1 152	1 152	1 152	1 152	1 152	1 152				
1 136	1 136	1 136	1 136	1 136	1 136				

DIMENSIONS	4.1	Mast tilt, $\alpha = \text{forward}/\beta$	degrees
	4.2	Height of mast, lowered	h ₁ (mm)
	4.3	Free lift \uparrow	h ₂ (mm)
	4.4	Lift height \uparrow	h ₃ (mm)
	4.5	Height of mast, extended \blacklozenge	h ₄ (mm)
	4.7	Overhead guard height \blacksquare	h ₅ (mm)
	4.8	Seat height \circ	h ₇ (mm)
	4.12	Towing coupling height	h ₁₀ (mm)
	4.19	Overall length	l ₁ (mm)
	4.20	Length to face of forks	l ₂ (mm)
	4.21	Overall width, standard/wide/dual drive	b ₁ /b ₂ (mm)
	4.22	Fork dimensions	s/e/l (mm)
	4.23	Fork carriage DIN 15173. Class, A/B	
	4.24	Fork carriage width \bullet	b ₃ (mm)
	4.31	Ground clearance under mast, with load	m ₁ (mm)
	4.32	Ground clearance, centre of wheelbase	m ₂ (mm)
	4.33	Aisle width with pallets 1 000 mm x 1 200 mm wide	Ast (mm)
	4.34	Aisle width with pallets 800 mm x 1 200 mm long	Ast (mm)
	4.35	Outer turning radius	W ₁ (mm)
4.36	Inner turning radius	b ₁₃ (mm)	

6F	10B	6F	10B	6F	10B	6F	10B	6F	10B		
2 175	2 175	2 175	2 175	2 175	2 175	2 175	2 175	2 175	2 175		
100	100	100	100	100	100	100	100	100	100		
3 000	3 000	3 000	3 000	3 000	3 000	3 000	3 000	3 000	3 000		
3 815	3 815	3 815	3 815	3 815	3 815	3 815	3 815	3 815	3 815		
2 258	2 258	2 258	2 258	2 258	2 258	2 258	2 258	2 258	2 258		
1 159	1 159	1 159	1 159	1 159	1 159	1 159	1 159	1 159	1 159		
429	429	429	429	429	429	429	429	429	429		
3 945	3 945	4 176	4 176	4 176	4 176	4 176	4 176	4 197	4 197		
2 945	2 945	2 976	2 976	2 976	2 976	2 976	2 976	2 997	2 997		
1 402	1 485	1 773	1 402	1 485	1 773	1 402	1 485	1 773	1 402	1 485	1 773
50 x 120 x 1 000	50 x 120 x 1 000	50 x 120 x 1 200	50 x 120 x 1 200	50 x 120 x 1 200	50 x 120 x 1 200	50 x 120 x 1 200	50 x 120 x 1 200	50 x 120 x 1 200	50 x 120 x 1 200		
III A	III A	III A	III A	III A	III A	III A	III A	III A	III A		
1 219	1 219	1 219	1 219	1 219	1 219	1 219	1 219	1 219	1 219		
151	151	150	150	150	150	150	150	150	150		
194	194	194	194	194	194	194	194	194	194		
4 292	4 292	4 321	4 321	4 321	4 321	4 321	4 321	4 321	4 321		
4 492	4 492	4 521	4 521	4 521	4 521	4 521	4 521	4 521	4 521		
2 570	2 570	2 599	2 599	2 599	2 599	2 599	2 599	2 619	2 619		
50	50	50	50	50	50	50	50	50	50		

PERFORMANCE	5.1	Travel speed with/without load	km/hr
	5.2	Lifting speed with/without load	m/sec
	5.3	Lowering speed with/without load	m/sec
	5.5	Drawbar pull with/without load @ 1,6 km/h	N
	5.6	Maximum drawbar pull with/without load	N
	5.7	Gradeability with/without load @ 4,8 km/h \dagger	%
	5.8	Maximum gradeability with/without load @1,6 km/h \dagger	%
	5.10	Service brake	

20,6	21,1	24,0	24,5	20,6	21,1	24,0	24,5	20,6	21,1
0,62	0,67	0,62	0,67	0,62	0,67	0,62	0,67	0,45	0,49
0,55	0,47	0,55	0,47	0,55	0,47	0,55	0,47	0,51	0,42
22 800	17 500	29 900	17 500	22 700	18 000	29 800	18 000	22 700	17 000
25 900	17 500	35 600	17 500	25 800	18 000	35 500	18 000	25 700	17 000
18,2	29,6	21,7	29,6	17,0	28,7	20,4	28,7	16,6	27,1
24,6	29,6	32,8	29,6	23,1	28,7	30,8	28,7	22,0	27,1
Hydraulic	Hydraulic	Hydraulic	Hydraulic	Hydraulic	Hydraulic	Hydraulic	Hydraulic	Hydraulic	Hydraulic

ENGINE	7.1	Engine manufacturer/Type \blacklozenge	
	7.2	Engine output, in accordance with ISO1585	kW
	7.3	Governed speed	rpm
	7.4	Number of cylinders/displacements	cm ³
	7.5	Fuel consumption in accordance with VDI cycle	l/h (DSL) or kg/h (LPG)

Kubota 3.6L	Kubota 3.6L	Kubota 3.6L	Kubota 3.6L	Kubota 3.6L					
57	57	57	57	57					
2 400	2 400	2 400	2 400	2 400					
4	3 620	4	3 620	4	3 620	4	3 620	4	3 620
5,98	6,21	6,05	6,26	6,72					

OTHER	8.1	Drive control	
	8.2	Working pressure for attachments	bar
	8.3	Oil flow for attachments	l/min
	8.4	Average noise level at operator's ear no cab/cab (Lpaz) *	dB (A)
		Guaranteed sound power 2001/14/EC (Lwaz)	dB
8.5	Towing coupling type		

Automatic	Automatic	Automatic	Automatic	Automatic					
155	155	155	155	155					
83,3	83,3	83,3	83,3	83,3					
80	80	80	80	80	80	80	80	80	80
105	105	105	105	105	105				
Pin	Pin	Pin	Pin	Pin					

Specification data is based on VDI 2198

Equipment and weight:

Weights (line 2.1) are based on the following specifications:

Complete truck with 3 050 mm (H4.0FT), 2 800 mm (H4.5-5.5FT) 2-stage limited free lift mast, standard carriage, 1 000 mm (H4.0FT) / 1 200 mm (H4.5-5.5FT) forks, manual hydraulics, overhead guard and standard pneumatic shaped solid drive and steer tyres.

HYSTER	HYSTER	HYSTER	HYSTER	HYSTER	HYSTER	HYSTER	1.1
H4.5FTS5	H4.5FT6	H4.5FT6	H5.0FT	H5.0FT	H5.5FT	H5.5FT	1.2
Fortens	Fortens	Fortens	Fortens	Fortens	Fortens	Fortens	
Kubota 3.6L Basic Powershift 2-speed	Kubota 3.6L Basic Powershift 1-speed	Kubota 3.6L Basic Powershift 2-speed	Kubota 3.6L Basic Powershift 1-speed	Kubota 3.6L Basic Powershift 2-speed	Kubota 3.6L Basic Powershift 1-speed	Kubota 3.6L Basic Powershift 2-speed	
ADS Drum	Wet Brakes	Wet Brakes	Wet Brakes	Wet Brakes	Wet Brakes	Wet Brakes	
Diesel	Diesel	Diesel	Diesel	Diesel	Diesel	Diesel	1.3
Seat	Seat	Seat	Seat	Seat	Seat	Seat	1.4
4 500	4 500	4 500	5 000	5 000	5 500	5 500	1.5
500	600	600	600	600	600	600	1.6
522,1	590	590	590	590	590	590	1.8
1 830	2 100	2 100	2 100	2 100	2 100	2 100	1.9

CHARACTERISTICS

6 630	7 224	7 224	7 523	7 523	7 808	7 808	2.1
9 496	1 216	10 596	1 164	10 596	1 164	11 241	1 272
2 829	3 801	3 473	3 751	3 473	3 751	3 406	4 117

WEIGHTS

SE	SE	SE	SE	SE	SE	SE	3.1
250 x 15	300 x 15	300 x 15	300 x 15	300 x 15	300 x 15	300 x 15	3.2
7,00 x 12	28 x 9 - 15	28 x 9 - 15	28 x 9 - 15	28 x 9 - 15	28 x 9 - 15	28 x 9 - 15	3.3
2X 2	2X 2	2X 2	2X 2	2X 2	2X 2	2X 2	3.5
1 152	1 150	1 150	1 150	1 150	1 150	1 150	3.6
1 136	1 136	1 136	1 136	1 136	1 136	1 136	3.7

WHEELS & TYRES

6F	10B	6F	10B	6F	10B	6F	10B	6F	10B	6F	10B	6F	10B	4.1	
2 215	2 215	2 215	2 215	2 215	2 215	2 215	2 215	2 215	2 215	2 215	2 215	2 215	2 215	4.2	
100	100	100	100	100	100	100	100	100	100	100	100	100	100	4.3	
2 740	2 740	2 740	2 740	2 740	2 740	2 740	2 740	2 740	2 740	2 740	2 740	2 740	2 740	4.4	
3 730	3 730	3 730	3 730	3 730	3 730	3 730	3 730	3 730	3 730	3 730	3 730	3 730	3 730	4.5	
2 258	2 300	2 300	2 300	2 300	2 300	2 300	2 300	2 300	2 300	2 300	2 300	2 300	2 300	4.7	
1 159	1 201	1 201	1 201	1 201	1 201	1 201	1 201	1 201	1 201	1 201	1 201	1 201	1 201	4.8	
429	472	472	472	472	472	472	472	472	472	472	472	472	472	4.12	
4 197	4 456	4 456	4 499	4 499	4 499	4 499	4 499	4 499	4 499	4 540	4 540	4 540	4 540	4.19	
2 997	3 256	3 256	3 299	3 299	3 299	3 299	3 299	3 299	3 299	3 340	3 340	3 340	3 340	4.20	
1 402	1 485	1 773	1 450	1 575	1 875	1 450	1 575	1 875	1 450	1 575	1 875	1 450	1 575	1 875	4.21
60 x 150 x 1 200	60 x 150 x 1 200	60 x 150 x 1 200	60 x 150 x 1 200	60 x 150 x 1 200	60 x 150 x 1 200	60 x 150 x 1 200	60 x 150 x 1 200	60 x 150 x 1 200	60 x 150 x 1 200	60 x 150 x 1 200	60 x 150 x 1 200	60 x 150 x 1 200	60 x 150 x 1 200	4.22	
IV A	IV A	IV A	IV A	IV A	IV A	IV A	IV A	IV A	IV A	IV A	IV A	IV A	IV A	4.23	
1 219	1 219	1 219	1 219	1 219	1 219	1 219	1 219	1 219	1 219	1 219	1 219	1 219	1 219	4.24	
194	194	194	194	194	194	194	194	194	194	194	194	194	194	4.31	
194	237	237	237	237	237	237	237	237	237	237	237	237	237	4.32	
4 341	4 627	4 627	4 667	4 667	4 667	4 667	4 667	4 667	4 667	4 705	4 705	4 705	4 705	4.33	
4 541	4 827	4 827	4 867	4 867	4 867	4 867	4 867	4 867	4 867	4 905	4 905	4 905	4 905	4.34	
2 619	2 837	2 837	2 877	2 877	2 877	2 877	2 877	2 877	2 877	2 915	2 915	2 915	2 915	4.35	
50	131	131	131	131	131	131	131	131	131	131	131	131	131	4.3	

DIMENSIONS

24,0	24,5	19,3	19,6	25,3	25,7	19,3	19,6	25,3	25,7	19,3	19,6	25,3	25,7	5.1
0,45	0,49	0,45	0,49	0,45	0,49	0,45	0,49	0,45	0,49	0,45	0,49	0,45	0,49	5.2
0,51	0,42	0,51	0,42	0,51	0,42	0,51	0,42	0,51	0,42	0,51	0,42	0,51	0,42	5.3
29 700	17 000	24 000	21 300	28 300	21 300	23 900	20 900	28 100	20 900	23 700	20 600	28 000	20 600	5.5
35 400	17 000	27 500	21 300	33 400	21 300	27 300	20 900	33 200	20 900	27 200	20 600	33 100	20 600	5.6
19,0	27,1	15,7	31,5	17,5	31,5	14,6	26,6	16,3	26,6	13,7	27,9	15,3	27,9	5.7
30,0	27,1	21,6	31,5	25,7	31,5	20,1	29,6	23,9	29,6	18,9	27,9	22,4	27,9	5.8
Hydraulic	Hydraulic	Hydraulic	Hydraulic	Hydraulic	Hydraulic	Hydraulic	Hydraulic	Hydraulic	Hydraulic	Hydraulic	Hydraulic	Hydraulic	Hydraulic	5.10

PERFORMANCE

Kubota 3.6L	Kubota 3.6L	Kubota 3.6L	Kubota 3.6L	Kubota 3.6L	Kubota 3.6L	Kubota 3.6	7.1
57	57	57	57	57	57	57	7.2
2 400	2 400	2 400	2 400	2 400	2 400	2 400	7.3
4	3 620	4	3 620	4	3 620	4	3 620
6,72	7,22	7,06	7,93	7,55	8,63	8,02*	7.5

ENGINE

Automatic	Automatic	Automatic	Automatic	Automatic	Automatic	Automatic	8.1
155	155	155	155	155	155	155	8.2
83,3	83,3	83,3	83,3	83,3	83,3	83,3	8.3
80	80	80	80	80	80	80	80
105	105	105	105	105	105	105	8.4
Pin	Pin	Pin	Pin	Pin	Pin	Pin	8.5

OTHER

The Kubota V3600 Diesel engine is only available in territories with category 1 diesel fuel, which contains sulphur levels of over 500ppm. This engine is not compatible with (<500ppm) or Ultra-Low (<15ppm) sulphur diesel fuel

Fortens Advance (1-speed) H4.0FT, H4.5FT, H5.0FT, H5.5FT

CHARACTERISTICS	1.1	Manufacturer	HYSTER									
	1.2	Model designation	H4.0FT5		H4.0FT5		H4.0FT6		H4.0FT6		H4.5FTS5	
		Model - Manufacturer designation	Fortens Advance		Fortens Advance		Fortens Advance		Fortens Advance		Fortens Advance	
		Engine/Transmission	Kubota 3.8L DuraMatch		GM 4.3L DuraMatch		Kubota 3.8L DuraMatch		GM 4.3L DuraMatch		Kubota 3.8L DuraMatch	
		Brake Type	ADS Drum		ADS Drum		ADS Drum		ADS Drum		ADS Drum	
	1.3	Power: battery, diesel, LPG, electric mains	Diesel		LPG		Diesel		LPG		Diesel	
	1.4	Operation: manual, pedestrian, stand, seat, orderpicker	Seat		Seat		Seat		Seat		Seat	
	1.5	Load capacity	4 000		4 000		4 000		4 000		4 500	
	1.6	Load centre	500		500		600		600		500	
	1.8	Load distance	522,1		522,1		522,1		522,1		522,1	
1.9	Wheelbase	1 830		1 830		1 830		1 830		1 830		

WEIGHTS	2.1	Unladen weight	6 298																			
	2.2	Axle loading with load, front/rear	8 849		1 077		8 464		1 198		8 910		1 390		8 999		1 243		9 496		1 216	
	2.3	Axle loading without load, front/rear	2 923		3 375		2 603		3 429		3 003		3 669		2 561		3 682		2 829		3 801	

WHEELS & TYRES	3.1	Tyres: L=pneumatic, V=solid, SE=pneumatic-shaped solid	SE															
	3.2	Tyre size, front	250 x 15		250 x 15		250 x 15		250 x 15		250 x 15							
	3.3	Tyre size, rear	7,00 x 12		7,00 x 12		7,00 x 12		7,00 x 12		7,00 x 12							
	3.5	Number of wheels, front/rear (X = driven)	2X		2		2X		2		2X		2		2X		2	
	3.6	Track width, front	1 152		1 152		1 152		1 152		1 152		1 152					
3.7	Track width, rear	1 136		1 136		1 136		1 136		1 136		1 136						

DIMENSIONS	4.1	Mast tilt, $\alpha = \text{forward}/\beta$	degrees											
	4.2	Height of mast, lowered	2 175		2 175		2 175		2 175		2 215			
	4.3	Free lift \uparrow	100		100		100		100		100			
	4.4	Lift height \uparrow	3 000		3 000		3 000		3 000		2 740			
	4.5	Height of mast, extended \blacklozenge	3 815		3 815		3 815		3 815		3 730			
	4.7	Overhead guard height \blacksquare	2 258		2 258		2 258		2 258		2 258			
	4.8	Seat height \circ	1 159		1 159		1 159		1 159		1 159			
	4.12	Towing coupling height	429		429		429		429		429			
	4.19	Overall length	3 945		3 945		4 176		4 176		4 197			
	4.20	Length to face of forks	2 945		2 945		2 976		2 976		2 997			
	4.21	Overall width, standard/wide/dual drive	1 402	1 485	1 773	1 402	1 485	1 773	1 402	1 485	1 773	1 402	1 485	1 773
	4.22	Fork dimensions	50 x 120 x 1 000		50 x 120 x 1 000		50 x 120 x 1 200		50 x 120 x 1 200		60 x 150 x 1 200			
	4.23	Fork carriage DIN 15173. Class, A/B	III A		III A		III A		III A		IV A			
	4.24	Fork carriage width \bullet	1 219		1 219		1 219		1 219		1 219			
	4.31	Ground clearance under mast, with load	151		151		150		150		194			
	4.32	Ground clearance, centre of wheelbase	194		194		194		194		194			
	4.33	Aisle width with pallets 1 000 mm x 1 200 mm wide \blacklozenge	4 292		4 292		4 321		4 321		4 341			
	4.34	Aisle width with pallets 800 mm x 1 200 mm long \blacklozenge	4 492		4 492		4 521		4 521		4 541			
	4.35	Outer turning radius	2 570		2 570		2 599		2 599		2 619			
	4.36	Inner turning radius	50		50		50		50		50			

PERFORMANCE	5.1	Travel speed with/without load	19,3		19,8		18,7		19,5		19,3		19,8	
	5.2	Lifting speed with/without load	0,62		0,63		0,61		0,63		0,62		0,63	
	5.3	Lowering speed with/without load	0,55		0,47		0,55		0,47		0,55		0,47	
	5.5	Drawbar pull with/without load @ 1,6 km/h	24 400		17 500		24 400		17 500		24 400		18 000	
	5.6	Maximum drawbar pull with/without load	27 500		17 500		27 600		16 800		27 400		18 000	
	5.7	Gradeability with/without load @ 4,8 km/h \uparrow	19,7		29,6		20,9		29,6		18,5		28,7	
	5.8	Maximum gradeability with/without load @1,6 km/h \uparrow	26,4		29,6		27,1		29,6		24,8		28,7	
	5.10	Service brake	Hydraulic		Hydraulic		Hydraulic		Hydraulic		Hydraulic		Hydraulic	

ENGINE	7.1	Engine manufacturer/Type \blacklozenge	Kubota 3.8L											
	7.2	Engine output, in accordance with ISO1585	55		77		55		77		55			
	7.3	Governed speed	2 200		2 400		2 200		2 400		2 200			
	7.4	Number of cylinders/displacements	4		3 769		6		4 302		4		3 769	
	7.5	Fuel consumption in accordance with VDI cycle	4,01		4,96		4,08		5,02		4,73			

OTHER	8.1	Drive control	Automatic											
	8.2	Working pressure for attachments	155		155		155		155		155			
	8.3	Oil flow for attachments	83,3		83,3		83,3		83,3		83,3			
	8.4	Average noise level at operator's ear no cab/cab (Lpaz) \star	79		79		82		80		79		79	
	8.5	Guaranteed sound power 2001/14/EC (Lwaz)	104		105		104		105		104			
	Towing coupling type	Pin		Pin		Pin		Pin		Pin				

Specification data is based on VDI 2198

Equipment and weight:

Weights (line 2.1) are based on the following specifications:

Complete truck with 3 050 mm (H4.0FT), 2 800 mm (H4.5-5.5FT) 2-stage limited free lift mast, standard carriage, 1 000 mm (H4.0FT) / 1 200 mm (H4.5-5.5FT) forks, e-hydraulics, overhead guard and standard pneumatic shaped solid drive and steer tyres.

HYSTER	HYSTER	HYSTER	HYSTER	HYSTER	HYSTER	HYSTER	
H4.5FTS5	H4.5FT6	H4.5FT6	H5.0FT	H5.0FT	H5.5FT	H5.5FT	1.1
Fortens Advance	Fortens Advance	Fortens Advance	Fortens Advance	Fortens Advance	Fortens Advance	Fortens Advance	1.2
GM 4.3L DuraMatch	Kubota 3.8L DuraMatch	GM 4.3L DuraMatch	Kubota 3.8L DuraMatch	GM 4.3L DuraMatch	Kubota 3.8L DuraMatch	GM 4.3L DuraMatch	
ADS Drum	Wet Brakes	Wet Brakes	Wet Brakes	Wet Brakes	Wet Brakes	Wet Brakes	
LPG	Diesel	LPG	Diesel	LPG	Diesel	LPG	1.3
Seat	Seat	Seat	Seat	Seat	Seat	Seat	1.4
4 500	4 500	4 500	5 000	5 000	5 500	5 500	1.5
500	600	600	600	600	600	600	1.6
522,1	590	590	590	590	590	590	1.8
1 830	2 100	2 100	2 100	2 100	2 100	2 100	1.9

CHARACTERISTICS

6 368	7 224		6 939		7 523		7 244		7 808		7 529		2.1	
9 095	1 356	10 596	1 164	10 265	1 210	11 241	1 272	10 913	1 320	11 882	1 370	11 555	1 417	2.2
2 526	3 842	3 473	3 751	3 152	3 787	3 406	4 117	3 089	4 155	3 335	4 474	3 016	4 513	2.3

WEIGHTS

SE		SE		SE		SE		SE		SE		SE		
250 x 15		300 x 15		300 x 15		300 x 15		300 x 15		300 x 15		300 x 15		3.1
7,00 x 12		28 x 9 - 15		28 x 9 - 15		28 x 9 - 15		28 x 9 - 15		28 x 9 - 15		28 x 9 - 15		3.2
2X	2	2X	2	2X	2	2X	2	2X	2	2X	2	2X	2	3.3
1 152		1 150		1 150		1 150		1 150		1 150		1 150		3.5
1 136		1 136		1 136		1 136		1 136		1 136		1 136		3.6
														3.7

WHEELS & TYRES

6	10	6	10	6	10	6	10	6	10	6	10	6	10		
2 215		2 215		2 215		2 215		2 215		2 215		2 215		4.1	
100		100		100		100		100		100		100		4.2	
2 740		2 740		2 740		2 740		2 740		2 740		2 740		4.3	
3 730		3 730		3 730		3 730		3 730		3 730		3 730		4.4	
2 258		2 300		2 300		2 300		2 300		2 300		2 300		4.5	
1 159		1 201		1 201		1 201		1 201		1 201		1 201		4.6	
429		472		472		472		472		472		472		4.7	
4 197		4 456		4 456		4 499		4 499		4 540		4 540		4.8	
2 997		3 256		3 256		3 299		3 299		3 340		3 340		4.9	
1 402	1 485	1 773	1 450	1 575	1 875	1 450	1 575	1 875	1 450	1 575	1 875	1 450	1 575	1 875	4.21
60 x 150 x 1 200		60 x 150 x 1 200		60 x 150 x 1 200		60 x 150 x 1 200		60 x 150 x 1 200		60 x 150 x 1 200		60 x 150 x 1 200		4.22	
IV A		IV A		IV A		IV A		IV A		IV A		IV A		4.23	
1 219		1 219		1 219		1 219		1 219		1 219		1 219		4.24	
194		194		194		194		194		194		194		4.31	
194		237		237		237		237		237		237		4.32	
4 341		4 627		4 627		4 667		4 667		4 705		4 705		4.33	
4 541		4 827		4 827		4 867		4 867		4 905		4 905		4.34	
2 619		2 837		2 837		2 877		2 877		2 915		2 915		4.35	
50		131		131		131		131		131		131		4.36	

DIMENSIONS

18,7	19,5	18,1	18,4	18,2	18,5	18,1	18,4	18,2	18,5	18,1	18,4	18,2	18,5	5.1
0,48	0,49	0,45	0,46	0,48	0,49	0,45	0,46	0,48	0,49	0,45	0,46	0,48	0,49	5.2
0,51	0,42	0,51	0,42	0,51	0,42	0,51	0,42	0,51	0,42	0,51	0,42	0,51	0,42	5.3
24 300	17 000	25 700	21 300	24 500	21 300	25 600	20 900	24 400	20 900	25 500	20 600	24 200	20 600	5.5
27 500	16 300	29 200	21 300	28 100	20 200	29 100	20 900	28 000	20 000	29 000	20 600	28 000	19 700	5.6
19,0	27,1	17,1	31,5	17,5	31,1	15,9	26,6	16,3	29,4	14,9	27,9	16,5	27,7	5.7
24,8	27,1	23,3	31,5	22,9	31,1	21,7	29,6	21,3	29,4	20,3	27,9	21,7	27,7	5.8
Hydraulic		Hydraulic		Hydraulic		Hydraulic		Hydraulic		Hydraulic		Hydraulic		5.10

PERFORMANCE

GM 4.3L	Kubota 3.8L	GM 4.3L	Kubota 3.8L	GM 4.3L	Kubota 3.8L	GM 4.3L		
77	55	77	55	77	55	77	7.1	
2 400	2 200	2 400	2 200	2 400	2 200	2 400	7.2	
6	4 302	4	3 769	6	4 302	4	3 769	7.3
5,25	5,21	5,33	5,90	5,54	6,56	5,76	7.4	
							7.5	

ENGINE

Automatic	Automatic	Automatic	Automatic	Automatic	Automatic	Automatic		
155	155	155	155	155	155	155	8.1	
83,3	83,3	83,3	83,3	83,3	83,3	83,3	8.2	
82	80	79	79	82	80	79	79	8.3
105	104	105	104	105	104	105	8.4	
Pin	Pin	Pin	Pin	Pin	Pin	Pin	8.5	

OTHER

Fortens Advance (2-speed) H4.0FT, H4.5FT, H5.0FT, H5.5FT

CHARACTERISTICS	1.1	Manufacturer		HYSTER	HYSTER	HYSTER	HYSTER	HYSTER	
	1.2	Model designation		H4.0FT5	H4.0FT5	H4.0FT6	H4.0FT6	H4.5FTS5	
		Model - Manufacturer designation		Fortens Advance	Fortens Advance	Fortens Advance	Fortens Advance	Fortens Advance	
		Engine/Transmission		Kubota 3.8L	GM 4.3L	Kubota 3.8L	GM 4.3L	Kubota 3.8L	
		Brake Type		DuraMatch 2	DuraMatch 2	DuraMatch 2	DuraMatch 2	DuraMatch 2	
	1.3	Power: battery, diesel, LPG, electric mains		ADS Drum or Wet Brakes	ADS Drum or Wet Brakes	ADS Drum or Wet Brakes	ADS Drum or Wet Brakes	ADS Drum or Wet Brakes	
	1.4	Operation: manual, pedestrian, stand, seat, orderpicker		Diesel	LPG	Diesel	LPG	Diesel	
	1.5	Load capacity	Q (kg)	Seat	Seat	Seat	Seat	Seat	
	1.6	Load centre	c (mm)	4 000	4 000	4 000	4 000	4 500	
	1.8	Load distance	x (mm)	500	500	600	600	500	
1.9	Wheelbase	y (mm)	522,1	522,1	522,1	522,1	522,1		
			1 830	1 830	1 830	1 830	1 830		
WEIGHTS	2.1	Unladen weight	kg	6 298	6 033	6 672	6 243	6 630	
	2.2	Axle loading with load, front/rear	kg	8 849	1 077	8 464	1 198	8 910	1 390
	2.3	Axle loading without load, front/rear	kg	2 923	3 375	2 603	3 429	3 003	3 669
			2 561	3 682	2 561	3 682	2 829	3 801	
WHEELS & TYRES	3.1	Tyres: L=pneumatic, V=solid, SE=pneumatic-shaped solid		SE	SE	SE	SE	SE	
	3.2	Tyre size, front		250 x 15	250 x 15	250 x 15	250 x 15	250 x 15	
	3.3	Tyre size, rear		7,00 x 12	7,00 x 12	7,00 x 12	7,00 x 12	7,00 x 12	
	3.5	Number of wheels, front/rear (X = driven)		2X 2	2X 2	2X 2	2X 2	2X 2	
	3.6	Track width, front	b ₁₀ (mm)	1 152	1 152	1 152	1 152	1 152	
	3.7	Track width, rear	b ₁₁ (mm)	1 136	1 136	1 136	1 136	1 136	
				1 136	1 136	1 136	1 136	1 136	
DIMENSIONS	4.1	Mast tilt, $\alpha = \text{forward}/\beta$	degrees	6	10	6	10	6	10
	4.2	Height of mast, lowered	h ₁ (mm)	2 175	2 175	2 175	2 175	2 175	2 215
	4.3	Free lift \uparrow	h ₂ (mm)	100	100	100	100	100	100
	4.4	Lift height \uparrow	h ₃ (mm)	3 000	3 000	3 000	3 000	3 000	2 740
	4.5	Height of mast, extended \blacklozenge	h ₄ (mm)	3 815	3 815	3 815	3 815	3 815	3 730
	4.7	Overhead guard height \blacksquare	h ₅ (mm)	2 258	2 258	2 258	2 258	2 258	2 258
	4.8	Seat height \circ	h ₇ (mm)	1 159	1 159	1 159	1 159	1 159	1 159
	4.12	Towing coupling height	h ₁₀ (mm)	429	429	429	429	429	429
	4.19	Overall length	l ₁ (mm)	3 945	3 945	4 176	4 176	4 176	4 197
	4.20	Length to face of forks	l ₂ (mm)	2 945	2 945	2 976	2 976	2 976	2 997
	4.21	Overall width, standard/wide/dual drive	b ₁ /b ₂ (mm)	1 402 1 485 1 773	1 402 1 485 1 773	1 402 1 485 1 773	1 402 1 485 1 773	1 402 1 485 1 773	1 402 1 485 1 773
	4.22	Fork dimensions	s/e/l (mm)	50 x 120 x 1 000	50 x 120 x 1 000	50 x 120 x 1 200	50 x 120 x 1 200	60 x 150 x 1 200	
	4.23	Fork carriage DIN 15173. Class, A/B		III A	III A	III A	III A	IV A	
	4.24	Fork carriage width \bullet	b3 (mm)	1 219	1 219	1 219	1 219	1 219	1 219
	4.31	Ground clearance under mast, with load	m ₁ (mm)	151	151	150	150	150	194
	4.32	Ground clearance, centre of wheelbase	m ₂ (mm)	194	194	194	194	194	194
4.33	Aisle width with pallets 1 000 mm x 1 200 mm wide \blacklozenge	Ast (mm)	4 292	4 292	4 321	4 321	4 321	4 341	
4.34	Aisle width with pallets 800 mm x 1 200 mm long \blacklozenge	Ast (mm)	4 492	4 492	4 521	4 521	4 521	4 541	
4.35	Outer turning radius	W ₈ (mm)	2 570	2 570	2 599	2 599	2 599	2 619	
4.36	Inner turning radius	b ₁₃ (mm)	50	50	50	50	50	50	
PERFORMANCE	5.1	Travel speed with/without load	km/h	22.4	22.9	23,3	24,4	22.4	22.9
	5.2	Lifting speed with/without load	m/sec	0.62	0.63	0.61	0.63	0.62	0.63
	5.3	Lowering speed with/without load	m/sec	0.55	0.47	0.55	0.47	0.55	0.47
	5.5	Drawbar pull with/without load @ 1,6 km/h	N	32 000	17 500	29 000	17 500	31 900	18 000
	5.6	Maximum drawbar pull with/without load	N	37 800	17 500	33 500	16 800	37 700	18 000
	5.7	Gradeability with/without load @ 4,8 km/h \uparrow	%	23,8	29,6	23,4	29,6	22,4	28,7
	5.8	Maximum gradeability with/without load @1,6 km/h \uparrow	%	35,5	29,6	32,7	29,6	33,3	28,7
	5.10	Service brake		Hydraulic	Hydraulic	Hydraulic	Hydraulic	Hydraulic	Hydraulic
				Hydraulic	Hydraulic	Hydraulic	Hydraulic	Hydraulic	Hydraulic
	ENGINE	7.1	Engine manufacturer/Type \blacklozenge		Kubota 3.8L	GM 4.3L	Kubota 3.8L	GM 4.3L	Kubota 3.8L
7.2		Engine output, in accordance with ISO1585	kW	55	77	55	77	55	
7.3		Governed speed	rpm	2 200	2 400	2 200	2 400	2 200	
7.4		Number of cylinders/displacements	cm ³	4 3 769	6 4 302	4 3 769	6 4 302	4 3 769	
7.5		Fuel consumption in accordance with VDI cycle	l/h (DSL) or kg/h (LPG)	4,18	5,2	4,23	5,2	4,73	
OTHER	8.1	Drive control		Automatic	Automatic	Automatic	Automatic	Automatic	
	8.2	Working pressure for attachments	bar	155	155	155	155	155	
	8.3	Oil flow for attachments	l/min	83,3	83,3	83,3	83,3	83,3	
	8.4	Average noise level at operator's ear no cab/cab (Lpaz) \star	dB (A)	79	79	82	80	79	79
		Guaranteed sound power 2001/14/EC (Lwaz)	dB	104	105	104	105	104	
	8.5	Towing coupling type		Pin	Pin	Pin	Pin	Pin	

Specification data is based on VDI 2198

Equipment and weight:

Weights (line 2.1) are based on the following specifications:

Complete truck with 3 050 mm (H4.0FT), 2 800 mm (H4.5-5.5FT) 2-stage limited free lift mast, standard carriage, 1 000 mm (H4.0FT) / 1 200 mm (H4.5-5.5FT) forks, e-hydraulics, overhead guard and standard pneumatic shaped solid drive and steer tyres.

HYSTER	HYSTER	HYSTER	HYSTER	HYSTER	HYSTER	HYSTER	1.1
H4.5FTS5	H4.5FT6	H4.5FT6	H5.0FT	H5.0FT	H5.5FT	H5.5FT	1.2
Fortens Advance	Fortens Advance	Fortens Advance	Fortens Advance	Fortens Advance	Fortens Advance	Fortens Advance	
GM 4.3L DuraMatch 2	Kubota 3.8L DuraMatch 2	GM 4.3L DuraMatch 2	Kubota 3.8L DuraMatch 2	GM 4.3L DuraMatch 2	Kubota 3.8L DuraMatch 2	GM 4.3L DuraMatch 2	
ADS Drum or Wet Brakes	Wet Brakes	Wet Brakes	Wet Brakes	Wet Brakes	Wet Brakes	Wet Brakes	
LPG	Diesel	LPG	Diesel	LPG	Diesel	LPG	1.3
Seat	Seat	Seat	Seat	Seat	Seat	Seat	1.4
4 500	4 500	4 500	5 000	5 000	5 500	5 500	1.5
500	600	600	600	600	600	600	1.6
522,1	590	590	590	590	590	590	1.8
1 830	2 100	2 100	2 100	2 100	2 100	2 100	1.9

CHARACTERISTICS

6 368	7 224	6 939	7 523	7 244	7 808	7 529	2.1							
9 095	1 356	10 596	1 164	10 265	1 210	11 241	1 272	10 913	1 320	11 882	1 370	11 555	1 417	2.2
2 526	3 842	3 473	3 751	3 152	3 787	3 406	4 117	3 089	4 155	3 335	4 474	3 016	4 513	2.3

WEIGHTS

SE	SE	SE	SE	SE	SE	SE	3.1
250 x 15	300 x 15	300 x 15	300 x 15	300 x 15	300 x 15	300 x 15	3.2
7,00 x 12	28 x 9 - 15	28 x 9 - 15	28 x 9 - 15	28 x 9 - 15	28 x 9 - 15	28 x 9 - 15	3.3
2X 2	2X 2	2X 2	2X 2	2X 2	2X 2	2X 2	3.5
1 152	1 150	1 150	1 150	1 150	1 150	1 150	3.6
1 136	1 136	1 136	1 136	1 136	1 136	1 136	3.7

WHEELS & TYRES

6	10	6	10	6	10	6	10	6	10	6	10	6	10	4.1	
2 215	2 215	2 215	2 215	2 215	2 215	2 215	2 215	2 215	2 215	2 215	2 215	2 215	2 215	4.2	
100	100	100	100	100	100	100	100	100	100	100	100	100	100	4.3	
2 740	2 740	2 740	2 740	2 740	2 740	2 740	2 740	2 740	2 740	2 740	2 740	2 740	2 740	4.4	
3 730	3 730	3 730	3 730	3 730	3 730	3 730	3 730	3 730	3 730	3 730	3 730	3 730	3 730	4.5	
2 258	2 300	2 300	2 300	2 300	2 300	2 300	2 300	2 300	2 300	2 300	2 300	2 300	2 300	4.7	
1 159	1 201	1 201	1 201	1 201	1 201	1 201	1 201	1 201	1 201	1 201	1 201	1 201	1 201	4.8	
429	472	472	472	472	472	472	472	472	472	472	472	472	472	4.12	
4 197	4 456	4 456	4 499	4 499	4 499	4 499	4 499	4 540	4 540	4 540	4 540	4 540	4 540	4.19	
2 997	3 256	3 256	3 299	3 299	3 299	3 299	3 299	3 340	3 340	3 340	3 340	3 340	3 340	4.20	
1 402	1 485	1 773	1 450	1 575	1 875	1 450	1 575	1 875	1 450	1 575	1 875	1 450	1 575	1 875	4.21
60 x 150 x 1 200	60 x 150 x 1 200	60 x 150 x 1 200	60 x 150 x 1 200	60 x 150 x 1 200	60 x 150 x 1 200	60 x 150 x 1 200	60 x 150 x 1 200	60 x 150 x 1 200	60 x 150 x 1 200	60 x 150 x 1 200	60 x 150 x 1 200	60 x 150 x 1 200	60 x 150 x 1 200	4.22	
IV A	IV A	IV A	IV A	IV A	IV A	IV A	IV A	IV A	IV A	IV A	IV A	IV A	IV A	4.23	
1 219	1 219	1 219	1 219	1 219	1 219	1 219	1 219	1 219	1 219	1 219	1 219	1 219	1 219	4.24	
194	194	194	194	194	194	194	194	194	194	194	194	194	194	4.31	
194	237	237	237	237	237	237	237	237	237	237	237	237	237	4.32	
4 341	4 627	4 627	4 667	4 667	4 667	4 667	4 667	4 705	4 705	4 705	4 705	4 705	4 705	4.33	
4 541	4 827	4 827	4 867	4 867	4 867	4 867	4 867	4 905	4 905	4 905	4 905	4 905	4 905	4.34	
2 619	2 837	2 837	2 877	2 877	2 877	2 877	2 877	2 915	2 915	2 915	2 915	2 915	2 915	4.35	
50	131	131	131	131	131	131	131	131	131	131	131	131	131	4.36	

DIMENSIONS

23,3	24,4	23,7	24,1	22,7	23,2	23,7	24,1	22,7	23,2	23,7	24,1	22,7	23,2	5.1
0,48	0,49	0,45	0,46	0,48	0,49	0,45	0,46	0,48	0,49	0,45	0,46	0,48	0,49	5.2
0,51	0,42	0,51	0,42	0,51	0,42	0,51	0,42	0,51	0,42	0,51	0,42	0,51	0,42	5.3
28 800	17 000	30 300	21 300	29 100	21 300	30 200	20 900	29 000	20 900	30 100	20 600	28 800	20 600	5.5
33 400	16 300	35 500	21 300	34 100	20 200	35 400	20 900	34 000	20 000	35 200	20 600	34 000	19 700	5.6
21,8	27,1	19,2	31,5	19,6	31,1	17,8	29,6	18,3	29,4	16,7	27,9	18,6	27,7	5.7
29,8	27,1	27,7	31,5	27,5	31,1	25,8	29,6	25,5	29,4	24,2	27,9	26,1	27,7	5.8
Hydraulic	Hydraulic	Hydraulic	Hydraulic	Hydraulic	Hydraulic	Hydraulic	Hydraulic	Hydraulic	Hydraulic	Hydraulic	Hydraulic	Hydraulic	Hydraulic	5.10

PERFORMANCE

GM 4.3L	Kubota 3.8L	GM 4.3L	Kubota 3.8L	GM 4.3L	Kubota 3.8L	GM 4.3L	7.1	
77	55	77	55	77	55	77	7.2	
2 400	2 200	2 400	2 200	2 400	2 200	2 400	7.3	
6	4 302	4	3 769	6	4 302	4	3 769	7.4
5,5	5,08	5,7	5,57	5,9	6,04	6,20	7.5	

ENGINE

Automatic	Automatic	Automatic	Automatic	Automatic	Automatic	Automatic	8.1							
155	155	155	155	155	155	155	8.2							
83,3	83,3	83,3	83,3	83,3	83,3	83,3	8.3							
82	80	79	79	80	80	79	79	80	80	79	79	80	80	8.4
105	104	105	104	105	104	105	104	105	104	105	104	105	104	
Pin	Pin	Pin	Pin	Pin	Pin	Pin	Pin	Pin	Pin	Pin	Pin	Pin	Pin	8.5

OTHER

Fortens Advance+ H4.0FT, H4.5FT, H5.0FT, H5.5FT

CHARACTERISTICS	1.1	Manufacturer		HYSTER	HYSTER	HYSTER	HYSTER	HYSTER				
	1.2	Model designation		H4.0FT5	H4.0FT5	H4.0FT6	H4.0FT6	H4.5FTS5				
		Model - Manufacturer designation		Fortens Advance+	Fortens Advance+	Fortens Advance+	Fortens Advance+	Fortens Advance+				
		Engine/Transmission		Kubota 3.8L	GM 4.3L	Kubota 3.8L	GM 4.3L	Kubota 3.8L				
		Brake Type		DuraMatch Plus 2	DuraMatch Plus 2	DuraMatch Plus 2	DuraMatch Plus 2	DuraMatch Plus 2				
	1.3	Power: battery, diesel, LPG, electric mains		Wet Brakes	Wet Brakes	Wet Brakes	Wet Brakes	Wet Brakes				
	1.4	Operation: manual, pedestrian, stand, seat, orderpicker		Diesel	LPG	Diesel	LPG	Diesel				
	1.5	Load capacity	Q (kg)	Seat	Seat	Seat	Seat	Seat				
	1.6	Load centre	c (mm)	4 000	4 000	4 000	4 000	4 500				
	1.8	Load distance	x (mm)	500	500	600	600	500				
1.9	Wheelbase	y (mm)	522,1	522,1	522,1	522,1	522,1					
			1 830	1 830	1 830	1 830	1 830					
WEIGHTS	2.1	Unladen weight	kg	6 298	6 033	6 672	6 243	6 630				
	2.2	Axle loading with load, front/rear	kg	8 849	1 077	8 464	1 198	8 910	1 390			
	2.3	Axle loading without load, front/rear	kg	2 923	3 375	2 603	3 429	3 003	3 669			
			2 561	3 682	2 829	3 801						
WHEELS & TYRES	3.1	Tyres: L=pneumatic, V=solid, SE=pneumatic-shaped solid		SE	SE	SE	SE	SE				
	3.2	Tyre size, front		250 x 15	250 x 15	250 x 15	250 x 15	250 x 15				
	3.3	Tyre size, rear		7,00 x 12	7,00 x 12	7,00 x 12	7,00 x 12	7,00 x 12				
	3.5	Number of wheels, front/rear (X = driven)		2X	2	2X	2	2X	2			
	3.6	Track width, front	b ₁₀ (mm)	1 152	1 152	1 152	1 152	1 152				
	3.7	Track width, rear	b ₁₁ (mm)	1 136	1 136	1 136	1 136	1 136				
DIMENSIONS	4.1	Mast tilt, $\alpha = \text{forward}/\beta$	degrees	6F	10B	6F	10B	6F	10B	6F	10B	
	4.2	Height of mast, lowered	h ₁ (mm)	2 175	2 175	2 175	2 175	2 175	2 175	2 215		
	4.3	Free lift \uparrow	h ₂ (mm)	100	100	100	100	100	100			
	4.4	Lift height \uparrow	h ₃ (mm)	3 000	3 000	3 000	3 000	3 000	2 740			
	4.5	Height of mast, extended \blacklozenge	h ₄ (mm)	3 815	3 815	3 815	3 815	3 815	3 730			
	4.7	Overhead guard height \blacksquare	h ₅ (mm)	2 258	2 258	2 258	2 258	2 258	2 258			
	4.8	Seat height \circ	h ₇ (mm)	1 159	1 159	1 159	1 159	1 159	1 159			
	4.12	Towing coupling height	h ₁₀ (mm)	429	429	429	429	429	429			
	4.19	Overall length	l ₁ (mm)	3 945	3 945	4 176	4 176	4 176	4 197			
	4.20	Length to face of forks	l ₂ (mm)	2 945	2 945	2 976	2 976	2 976	2 997			
	4.21	Overall width, standard/wide/dual drive	b ₁ /b ₂ (mm)	1 402	1 485	1 773	1 402	1 485	1 773	1 402	1 485	1 773
	4.22	Fork dimensions	s/e/l (mm)	60 x 150 x 1 200	60 x 150 x 1 200	60 x 150 x 1 200	60 x 150 x 1 200	60 x 150 x 1 200	60 x 150 x 1 200			
	4.23	Fork carriage DIN 15173. Class, A/B		III A	III A	III A	III A	III A	IV A			
	4.24	Fork carriage width \bullet	b3 (mm)	1 219	1 219	1 219	1 219	1 219	1 219			
	4.31	Ground clearance under mast, with load	m ₁ (mm)	151	151	150	150	150	194			
	4.32	Ground clearance, centre of wheelbase	m ₂ (mm)	194	194	194	194	194	194			
	4.33	Aisle width with pallets 1 000 mm x 1 200 mm wide	Ast (mm)	4 292	4 292	4 321	4 321	4 321	4 341			
	4.34	Aisle width with pallets 800 mm x 1 200 mm long	Ast (mm)	4 492	4 492	4 521	4 521	4 521	4 541			
	4.35	Outer turning radius	W ₈ (mm)	2 570	2 570	2 599	2 599	2 599	2 619			
	4.36	Inner turning radius	b ₁₃ (mm)	50	50	50	50	50	50			
PERFORMANCE	5.1	Travel speed with/without load	km/h	21,2	21,6	21,8	22,8	21,2	21,6			
	5.2	Lifting speed with/without load	m/sec	0,62	0,63	0,61	0,63	0,62	0,63			
	5.3	Lowering speed with/without load	m/sec	0,55	0,47	0,55	0,47	0,55	0,47			
	5.5	Drawbar pull with/without load @ 1,6 km/h	N	25 800	17 500	29 800	17 500	25 800	18 000			
	5.6	Maximum drawbar pull with/without load	N	25 800	17 500	44 200	16 800	25 800	18 000			
	5.7	Gradeability with/without load @ 4,8 km/h \uparrow	%	24,4	29,6	26,4	29,6	22,9	28,7			
	5.8	Maximum gradeability with/without load @ 1,6 km/h \uparrow	%	28,4	29,6	42,0	29,6	26,4	28,7			
	5.10	Service brake		Hydraulic	Hydraulic	Hydraulic	Hydraulic	Hydraulic	Hydraulic			
ENGINE	7.1	Engine manufacturer/Type \blacklozenge		Kubota 3.8L	GM 4.3L	Kubota 3.8L	GM 4.3L	Kubota 3.8L				
	7.2	Engine output, in accordance with ISO1585	kW	55	77	55	77	55				
	7.3	Governed speed	rpm	2 200	2 400	2 200	2 400	2 200				
	7.4	Number of cylinders/displacements	cm ³	4	3 769	6	4 302	4	3 769			
	7.5	Fuel consumption in accordance with VDI cycle	l/h (DSL) or kg/h (LPG)	TBA	TBA	TBA	TBA	TBA				
OTHER	8.1	Drive control		Automatic	Automatic	Automatic	Automatic	Automatic				
	8.2	Working pressure for attachments	bar	155	155	155	155	155				
	8.3	Oil flow for attachments	l/min	83,3	83,3	83,3	83,3	83,3				
	8.4	Average noise level at operator's ear no cab/cab (Lpaz) \star	dB (A)	79	79	82	80	79	79			
		Guaranteed sound power 2001/14/EC (Lwaz)	dB	104	105	104	105	104				
	8.5	Towing coupling type		Pin	Pin	Pin	Pin	Pin				

Specification data is based on VDI 2198

Equipment and weight:

Weights (line 2.1) are based on the following specifications:

Complete truck with 3 050 mm (H4.0FT), 2 800 mm (H4.5-5.5FT) 2-stage limited free lift mast, standard carriage, 1 000 mm (H4.0FT) / 1 200 mm (H4.5-5.5FT) forks, e-hydraulics, overhead guard and standard pneumatic shaped solid drive and steer tyres.

HYSTER	HYSTER	HYSTER	HYSTER	HYSTER	HYSTER	HYSTER	1.1
H4.5FTS5	H4.5FT6	H4.5FT6	H5.0FT	H5.0FT	H5.5FT	H5.5FT	1.2
Fortens Advance+	Fortens Advance+	Fortens Advance+	Fortens Advance+	Fortens Advance+	Fortens Advance+	Fortens Advance+	
GM 4.3L	Kubota 3.8L	GM 4.3L	Kubota 3.8L	GM 4.3L	Kubota 3.8L	GM 4.3L	
DuraMatch Plus 2	DuraMatch Plus 2	DuraMatch Plus 2	DuraMatch Plus 2	DuraMatch Plus 2	DuraMatch Plus 2	DuraMatch Plus 2	
Wet Brakes	Wet Brakes	Wet Brakes	Wet Brakes	Wet Brakes	Wet Brakes	Wet Brakes	
LPG	Diesel	LPG	Diesel	LPG	Diesel	LPG	1.3
Seat	Seat	Seat	Seat	Seat	Seat	Seat	1.4
4 500	4 500	4 500	5 000	5 000	5 500	5 500	1.5
500	600	600	600	600	600	600	1.6
522,1	590	590	590	590	590	590	1.8
1 830	2 100	2 100	2 100	2 100	2 100	2 100	1.9

CHARACTERISTICS

6 368	7 224	6 939	7 523	7 244	7 808	7 529	2.1
9 095	1 356	10 596	1 164	10 265	1 210	11 241	1 272
10 913	1 320	11 882	1 370	11 555	1 417		
2 526	3 842	3 473	3 751	3 152	3 787	3 406	4 117
3 089	4 155	3 335	4 474	3 016	4 513		

WEIGHTS

SE	SE	SE	SE	SE	SE	SE	3.1
250 x 15	300 x 15	300 x 15	300 x 15	300 x 15	300 x 15	300 x 15	3.2
7,00 x 12	28 x 9 - 15	28 x 9 - 15	28 x 9 - 15	28 x 9 - 15	28 x 9 - 15	28 x 9 - 15	3.3
2X	2	2X	2	2X	2	2X	2
1 152	1 150	1 150	1 150	1 150	1 150	1 150	3.6
1 136	1 136	1 136	1 136	1 136	1 136	1 136	3.7

WHEELS & TYRES

6F	10B	6F	10B	6F	10B	6F	10B	6F	10B	6F	10B	6F	10B	4.1	
2 215	2 215	2 215	2 215	2 215	2 215	2 215	2 215	2 215	2 215	2 215	2 215	2 215	2 215	4.2	
100	100	100	100	100	100	100	100	100	100	100	100	100	100	4.3	
2 740	2 740	2 740	2 740	2 740	2 740	2 740	2 740	2 740	2 740	2 740	2 740	2 740	2 740	4.4	
3 730	3 730	3 730	3 730	3 730	3 730	3 730	3 730	3 730	3 730	3 730	3 730	3 730	3 730	4.5	
2 258	2 300	2 300	2 300	2 300	2 300	2 300	2 300	2 300	2 300	2 300	2 300	2 300	2 300	4.7	
1 159	1 201	1 201	1 201	1 201	1 201	1 201	1 201	1 201	1 201	1 201	1 201	1 201	1 201	4.8	
429	472	472	472	472	472	472	472	472	472	472	472	472	472	4.12	
4 197	4 456	4 456	4 499	4 499	4 499	4 540	4 540	4 540	4 540	4 540	4 540	4 540	4 540	4.19	
2 997	3 256	3 256	3 299	3 299	3 340	3 340	3 340	3 340	3 340	3 340	3 340	3 340	3 340	4.20	
1 402	1 485	1 773	1 450	1 575	1 875	1 450	1 575	1 875	1 450	1 575	1 875	1 450	1 575	1 875	4.21
60 x 150 x 1 200	60 x 150 x 1 200	60 x 150 x 1 200	60 x 150 x 1 200	60 x 150 x 1 200	60 x 150 x 1 200	60 x 150 x 1 200	60 x 150 x 1 200	60 x 150 x 1 200	60 x 150 x 1 200	60 x 150 x 1 200	60 x 150 x 1 200	60 x 150 x 1 200	60 x 150 x 1 200	4.22	
IV A	IV A	IV A	IV A	IV A	IV A	IV A	IV A	IV A	IV A	IV A	IV A	IV A	IV A	4.23	
1 219	1 219	1 219	1 219	1 219	1 219	1 219	1 219	1 219	1 219	1 219	1 219	1 219	1 219	4.24	
194	194	194	194	194	194	194	194	194	194	194	194	194	194	4.31	
194	237	237	237	237	237	237	237	237	237	237	237	237	237	4.32	
4 341	4 627	4 627	4 667	4 667	4 667	4 705	4 705	4 705	4 705	4 705	4 705	4 705	4 705	4.33	
4 541	4 827	4 827	4 867	4 867	4 867	4 905	4 905	4 905	4 905	4 905	4 905	4 905	4 905	4.34	
2 619	2 837	2 837	2 877	2 877	2 877	2 915	2 915	2 915	2 915	2 915	2 915	2 915	2 915	4.35	
50	131	131	131	131	131	131	131	131	131	131	131	131	131	4.36	

DIMENSIONS

21,8	22,8	21,2	21,7	22,7	23,2	21,2	21,7	22,7	23,2	21,2	21,7	22,7	23,2	5.1
0,48	0,49	0,45	0,46	0,48	0,49	0,45	0,46	0,48	0,49	0,45	0,46	0,48	0,49	5.2
0,51	0,42	0,51	0,42	0,51	0,42	0,51	0,42	0,51	0,42	0,51	0,42	0,51	0,42	5.3
29 800	17 000	25 800	17 000	25 800	21 300	25 800	20 900	25 800	20 900	25 800	20 600	25 800	20 600	5.5
44 100	16 300	25 800	17 000	39 400	20 200	25 800	20 900	39 400	20 000	25 800	20 600	39 400	19 700	5.6
24,4	27,1	20,1	27,1	21,7	31,1	18,7	29,6	20,1	29,4	17,5	27,9	20,4	27,7	5.7
38,2	27,1	23,4	27,1	30,1	31,1	21,9	29,6	28,1	29,4	20,6	27,9	28,5	27,7	5.8
Hydraulic	Hydraulic	Hydraulic	Hydraulic	Hydraulic	Hydraulic	Hydraulic	Hydraulic	Hydraulic	Hydraulic	Hydraulic	Hydraulic	Hydraulic	Hydraulic	5.10

PERFORMANCE

GM 4.3L	Kubota 3.8L	GM 4.3L	Kubota 3.8L	GM 4.3L	Kubota 3.8L	GM 4.3L	7.1
77	55	77	55	77	55	77	7.2
2 400	2 200	2 400	2 200	2 400	2 200	2 400	7.3
6	4 302	4	3 769	6	4 302	4	3 769
6	4 302	4	3 769	6	4 302	4	3 769
TBA	TBA	TBA	TBA	TBA	TBA	TBA	7.5

ENGINE

Automatic	Automatic	Automatic	Automatic	Automatic	Automatic	Automatic	8.1
155	155	155	155	155	155	155	8.2
83,3	83,3	83,3	83,3	83,3	83,3	83,3	8.3
82	80	79	79	80	80	80	80
80	80	79	79	80	80	79	79
105	104	105	104	105	104	105	8.4
Pin	Pin	Pin	Pin	Pin	Pin	Pin	8.5

OTHER

Mast and capacity information

Masts H4.0FT5/FT6

	Maximum fork height (mm)	Back tilt	Overall lowered height (mm)	Overall Extended height (mm)	Free lift (top of forks) (mm)
2-Stage Limited Free Lift	3 050	10°	2 175	4 300 ✕	150 ▽
	3 650	10°	2 475	4 900 ✕	150 ▽
	4 250	10°	2 775	5 500 ✕	150 ▽
	4 950	6°	3 225	6 200 ✕	150 ▽
2-Stage Full Free Lift	3 075	10°	2 175	4 325 ✕	1 355 ▽
	3 675	10°	2 475	4 925 ✕	1 655 ▽
3-Stage Full Free Lift	4 415	6°	2 175	5 665 ✕	1 355 ▽
	4 950	6°	2 375	6 200 ✕	1 555 ▽
	5 250	6°	2 475	6 500 ✕	1 655 ▽
	5 550	6°	2 575	6 800 ✕	1 755 ▽
	6 000	6°	2 775	7 250 ✕	1 955 ▽

Masts H4.5FTS5-H5.5FT

	Maximum fork height (mm)	Back tilt	Overall lowered height (mm)	Overall Extended height (mm)	Free lift (top of forks) (mm)
2-Stage Limited Free Lift	2 800	10°	2 215	4 065 ✕	160 ▽
	3 400	10°	2 515	4 665 ✕	160 ▽
	4 000	10°	2 815	5 265 ✕	160 ▽
	4 700	6°	3 265	5 965 ✕	160 ▽
	5 300	6°	3 665	6 565 ✕	160 ▽
2-Stage Full Free Lift	2 825	10°	2 215	4 090 ✕	1 230 ▽
	3 425	10°	2 515	4 690 ✕	1 530 ▽
3-Stage Full Free Lift	4 415	6°	2 215	5 415 ✕	1 230 ▽
	5 000	6°	2 515	6 265 ✕	1 530 ▽
	5 300	6°	2 615	6 565 ✕	1 630 ▽

Values shown are for standard equipment. When using non-standard equipment, these values may change. Please contact your Hyster dealer for information.

H4.0FT5-H4.0FT6 - Capacity chart in kg @ 500 mm (a) or 600 mm (b) load centre

	Maximum fork height (mm)	Pneumatic Shaped Solid Tyres			
		Without sideshift		Without sideshift	
		H4.0FT5 (a)	H4.0T6 (b)	H4.0FT5 (a)	H4.0FT6 (b)
2-Stage Limited Free Lift	3 050	4 000	4 000	4 000	4 000
	3 650	4 000	4 000	4 000	4 000
	4 250	4 000	4 000	4 000	4 000
	4 950	3 890	3 890	3 890	3 890
2-Stage Full Free Lift	3 075	4 000	4 000	4 000	4 000
	3 675	4 000	4 000	4 000	4 000
3-Stage Full Free Lift	4 415	4 000	4 000	4 000	4 000
	4 950	3 880	3 880	3 880	3 810
	5 250	3 810	3 810	3 810	3 790
	5 550	3 730	3 740	3 730	3 710
	6 000	3 610	3 620	3 590	3 580

H4.0FT5-H4.0FT6 - Capacity chart in kg @ 500 mm (a) or 600 mm (b) load centre

	Maximum fork height (mm)	Michelin (Radial) Tyres			
		Without sideshift		Without sideshift	
		H4.0FT5 (a)	H4.0T6 (b)	H4.0FT5 (a)	H4.0FT6 (b)
2-Stage Limited Free Lift	3 050	4 000	4 000	4 000	4 000
	3 650	4 000	4 000	4 000	4 000
	4 250	4 000	4 000	4 000	4 000
	4 950	3 880	3 890	3 880	3 890
2-Stage Full Free Lift	3 075	4 000	4 000	4 000	4 000
	3 675	4 000	4 000	4 000	4 000
3-Stage Full Free Lift	4 415	4 000	4 000	4 000	4 000
	4 950	3 880 ◀	3 880 ◀	3 880 ◀	3 870 ◀
	5 250	3 800 ◀	3 810 ◀	3 800 ◀	3 790 ◀
	5 550	3 730 ✕	3 740 ✕	3 730 ✕	3 710 ✕
	6 000	3 610 ✕	3 620 ✕	3 590 ✕	3 580 ✕

H4.5FTS5-H5.5FT - Capacity chart in kg @ 500 mm (a) or 600 mm (b) load centre

	Maximum fork height (mm)	Pneumatic Shaped Solid Tyres								
		Without sideshift				Maximum fork height (mm)	With integral sideshift		With integral sideshift	
		H4.5FTS5 (a)	H4.0T6 (b)	H4.0FT5 (a)	H4.0FT6 (b)		H4.0FT5 (a)	H4.0FT6 (b)	H4.0FT5 (a)	H4.0FT6 (b)
2-Stage Limited Free Lift	2 800	4 500	4 500	5 000	5 500	2 800	4 500	4 500	5 000	5 500
	3 400	4 500	4 500	5 000	5 500	3 400	4 500	4 500	5 000	5 500
	4 000	4 500	4 500	5 000	5 500	4 000	4 480	4 500	5 000	5 500
	4 700	4 390	4 390	4 890	5 380	4 700	4 340	4 390	4 890	5 380
	5 300	4 240	4 250	4 740	5 230	5 300	4 160	4 250	4 740	5 230
2-Stage Full Free Lift	2 825	4 500	4 500	5 000	5 500	2 825	4 480	4 500	5 000	5 500
	3 425	4 500	4 500	5 000	5 500	3 425	4 460	4 500	5 000	5 500
3-Stage Full Free Lift	4 145	4 500	4 500	5 000	5 500	4 145	4 420	4 500	5 000	5 500
	5 000	4 300	4 310	4 800	5 290	5 000	4 200	4 310	4 800	5 290
	5 300	4 230	4 240	4 730	5 210	5 300	4 120	4 240	4 730	5 210

H4.5FTS5-H5.5FT - Capacity chart in kg @ 500 mm (a) or 600 mm (b) load centre

	Maximum fork height (mm)	Michelin (Radial) Tyres								
		Without sideshift		Without sideshift		Maximum fork height (mm)	With integral sideshift		With integral sideshift	
		H4.5FTS5 (a)	H4.5FT6 (b)	H5.0FT (b)	H5.5FT (b)		H4.5FTS5 (a)	H4.5FT6 (b)	H5.0FT (b)	H5.5FT (b)
2-Stage Limited Free Lift	2 800	4 500	4 500	5 000	5 500	2 800	4 500	4 500	5 000	5 500
	3 400	4 500	4 500	5 000	5 500	3 400	4 500	4 500	5 000	5 500
	4 000	4 500	4 500	5 000	5 500	4 000	4 480	4 500	5 000	5 500
	4 700	4 380	4 390	4 880	5 380 ◀	4 700	4 340	4 390	4 880	5 380 ◀
	5 300	4 230 ◀	4 250 ◀	4 730 ◀	5 220 ◀	5 300	4 160 ◀	4 250 ◀	4 730 ◀	5 220 ◀
2-Stage Full Free Lift	2 825	4 500	4 500	5 000	5 500	2 825	4 480	4 500	5 000	5 500
	3 425	4 500	4 500	5 000	5 500	3 425	4 460	4 500	5 000	5 500
3-Stage Full Free Lift	4 145	4 500	4 500	5 000	5 500	4 145	4 420	4 500	5 000	5 500
	5 000	4 270 ◀	4 310 ◀	4 800 ◀	5 290 ◀	5 000	4 200 ◀	4 310 ◀	4 800 ◀	5 290 ◀
	5 300	4 220 ✕	4 240 ◀	4 730 ✕	5 210 ✕	5 300	4 120 ✕	4 240 ◀	4 730 ✕	5 210 ✕

NOTES

To calculate truck capacities with alternative truck specifications to the ones shown in the above tables, please consult your Hyster dealer.

The rated capacities shown are for masts in a vertical position on trucks equipped with standard or sideshift carriage, and nominal length forks. Masts above the maximum fork heights shown in the mast table are classified as high lift, and depending on the tyre/tread configuration may require reduced capacity, restricted back tilt or wide tread.

Truck Dimensions

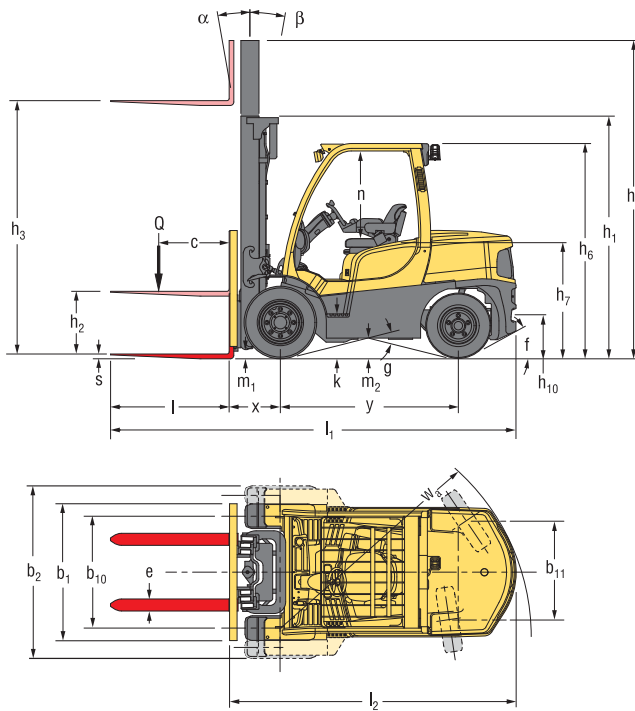

= Centre of gravity of unladen truck

$$Ast = W_a + x + l_6 + a \text{ (see lines 4.33 \& 4.34)}$$

a = Minimum operating clearance

(V.D.I. standard = 200 mm BITA recommendation = 300 mm)

l_6 = Load length

Dimensions (mm)	H4.0FT5	H4.0FT6	H4.5FT5	H4.5FT6	H5.0FT	H5.5FT
f	37%	27.5%	33%	32%	32%	28%
g	28,0°	28,0°	28,0°	30,0°	30,0°	30,0°
k	441	441	441	484	484	484
n	1 062	1 062	1 062	1 062	1 062	1 062

Rated Capacities

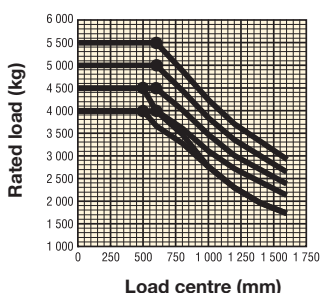

Load centre

Distance from front of forks to centre of gravity of load.

Rated load

Based on vertical masts up to 4 250 mm (H4.0FT) and 4 000 mm (H4.5-5.5FT).

NOTE:

Specifications are affected by the condition of the vehicle and how it is equipped, as well as the nature and condition of the operating area. If these specifications are critical, the proposed application should be discussed with your dealer.

- ¶ Top of forks
- ◆ Without load backrest
- h_6 subject to +/- 5 mm tolerance.
- Full-suspension seat in depressed position
- Subtract 32 mm without load backrest
- ◆ Stacking aisle width (lines 4.33 & 4.34) are based on the V.D.I. standard calculation as shown on illustration. The British Industrial Truck Association recommends the addition of 100 mm to the total clearance (dimension a) for extra operating margin at the rear of the truck.
- † Gradeability figures (lines 5.7 & 5.8) are provided for comparison of tractive performance, but are not intended to endorse the operation of the vehicle on the stated inclines. Follow instructions in the operating manual regarding operation on inclines.
- ⊞ Variable
- ◇ Measured according to the test cycles and based on the weighting values contained in EN12053
- * Noise levels are reduced by 3dB(A) with ECO-eLo mode engaged.
- ◆ The Kubota V3600 Diesel engine is only compatible with category 1 diesel fuel, which contains sulphur levels of over 500ppm.

The Kubota V3800 3.8L Diesel engine is equipped with a cooled EGR system, which requires the use of Low (<500ppm) or Ultra-Low (<15ppm) sulphur fuel.

Mast tables:

- ❖ With load backrest
- ▽ Without load backrest
- Wide tread or Dual Drive Wheels required
- * Dual Drive Wheels required

Notice

Care must be exercised when handling elevated loads. When the carriage and/or load is elevated, truck stability is reduced. It is important that mast tilt in either direction be kept to a minimum when loads are elevated. Operators must be trained and adhere to the instructions contained in the Operating Manual.

Hyster products are subject to change without notice. Lift trucks illustrated may feature optional equipment.



This truck conforms to the current EU requirements.

Product Packages

The Hyster Fortens™ range has been designed to match the vast range of application requirements and business objectives that customers demand.

The H4.0-5.5FT Series is available in several truck packages, with multiple powertrain combinations to choose from, to best match operational demands. Each configuration offers improved efficiency, advanced dependability, lower cost of operations and simple serviceability.

Model / Bundle	H4.0FT5			H4.0FT6		
DIESEL	Engine	Transmission	Brakes	Engine	Transmission	Brakes
Fortens	Kubota V3600 ☼	Electronic Powershift 1 or 2 speed	Drum	Kubota V3600 ☼	Electronic Powershift 1 or 2 speed	Drum
Fortens Advance	Kubota V3800 ☉	DuraMatch™ Electronic 1 or 2 speed	ADS Drum	Kubota V3800 ☉	DuraMatch™ Electronic 1 or 2 speed	ADS Drum
Fortens Advance	Kubota V3800 ☉	DuraMatch™ Electronic 2 speed	Wet	Kubota V3800 ☉	DuraMatch™ Electronic 2 speed	Wet
Fortens Advance+	Kubota V3800 ☉	DuraMatch™ Plus 2 speed	Wet	Kubota V3800 ☉	DuraMatch™ Plus 2 speed	Wet

Model / Bundle	H4.5FTS5			H4.5T6		
DIESEL	Engine	Transmission	Brakes	Engine	Transmission	Brakes
Fortens	Kubota V3600 ☼	Electronic Powershift 1 or 2 speed	Drum	Kubota V3600 ☼	Electronic Powershift 1 or 2 speed	Wet
Fortens Advance	Kubota V3800 ☉	DuraMatch™ Electronic 1 or 2 speed	ADS Drum	Kubota V3800 ☉	DuraMatch™ Electronic 1 or 2 speed	Wet
Fortens Advance	Kubota V3800 ☉	DuraMatch™ Electronic 2 speed	Wet	-	-	-
Fortens Advance+	Kubota V3800 ☉	DuraMatch™ Plus 2 speed	Wet	Kubota V3800 ☉	DuraMatch™ Plus 2 speed	Wet

Model / Bundle	H5.0FT			H5.5FT		
DIESEL	Engine	Transmission	Brakes	Engine	Transmission	Brakes
Fortens	Kubota V3600 ☼	Electronic Powershift 1 or 2 speed	Wet	Kubota V3600 ☼	Electronic Powershift 1 or 2 speed	Wet
Fortens Advance	Kubota V3800 ☉	DuraMatch™ Electronic 1 or 2 speed	Wet	Kubota V3800 ☉	DuraMatch™ Electronic 1 or 2 speed	Wet
Fortens Advance+	Kubota V3800 ☉	DuraMatch™ Plus 2 speed	Wet	Kubota V3800 ☉	DuraMatch™ Plus 2 speed	Wet

Model / Bundle	H4.0FT5			H4.0FT6		
LPG	Engine	Transmission	Brakes	Engine	Transmission	Brakes
Fortens Advance	GM 4.3L V6	DuraMatch™ Electronic 1 or 2 speed	ADS Drum	GM 4.3L V6	DuraMatch™ Electronic 1 or 2 speed	ADS Drum
Fortens Advance	GM 4.3L V6	DuraMatch™ Electronic 2 speed	Wet	GM 4.3L V6	DuraMatch™ Electronic 2 speed	Wet
Fortens Advance+	GM 4.3L V6	DuraMatch™ Plus 2 speed	Wet	GM 4.3L V6	DuraMatch™ Plus 2 speed	Wet

Model / Bundle	H4.5FTS5			H4.5T6		
Diesel	Engine	Transmission	Brakes	Engine	Transmission	Brakes
Fortens Advance	GM 4.3L V6	DuraMatch™ Electronic 1 or 2 speed	ADS Drum	GM 4.3L V6	DuraMatch™ Electronic 1 or 2 speed	Wet
Fortens Advance	GM 4.3L V6	DuraMatch™ Electronic 2 speed	Wet	-	-	-
Fortens Advance+	GM 4.3L V6	DuraMatch™ Plus 2 speed	Wet	GM 4.3L V6	DuraMatch™ Plus 2 speed	Wet

Model / Bundle	H5.0FT			H5.5FT		
Diesel	Engine	Transmission	Brakes	Engine	Transmission	Brakes
Fortens Advance	GM 4.3L V6	DuraMatch™ Electronic 1 or 2 speed	Wet	GM 4.3L V6	DuraMatch™ Electronic 1 or 2 speed	Wet
Fortens Advance+	GM 4.3L V6	DuraMatch™ Plus 2 speed	Wet	GM 4.3L V6	DuraMatch™ Plus 2 speed	Wet

Please refer to the Price List for full option configurations.

NOTES

☼ Kubota V3600 Diesel engine is only compatible with category 1 diesel fuel, which contains sulphur levels of over 500ppm.

☉ Kubota V3800 3.8L Diesel engine is equipped with a cooled EGR system, which requires the use of Low (<500ppm) or Ultra-Low (<15ppm) sulphur fuel.

Product Features

Fortens models feature the new Kubota V3600 4-cylinder IDI-T mechanically controlled turbocharged diesel engine with 57kW, for use in those markets where EU diesel exhaust standards are not currently applied. The engine will only operate with category 1 diesel fuel only, which contains sulphur levels of over 500ppm. It is not compatible with low or Ultra-low sulphur diesel.

This mechanically controlled engine is combined with a new electronic powershift transmission, available with one or two speeds and Cowl Mounted Mechanical Levers. Engine rpm, coolant temperature and oil pressure are monitored by the VSM.

Fortens Advance & Advance+ models feature the new Kubota V3800 E3 turbocharged diesel engine with 55.4 kW or the GM 4.3L V6 LPG engine with 77kW.

The new Kubota V3800 engine is equipped with a Cooled Exhaust Gas Recirculation (EGR) system which reduces the NOx emissions by re-circulating a part of the exhaust gases back into the engine to directly reduce NOx inside the engine. The EGR is self-contained and avoids the need for any fuel additive. It requires the use of Low (<500ppm) or Ultra-Low (<15ppm) sulphur fuel - Diesel fuel with a higher sulphur content will compromise emissions performance and result in damage to EGR system components. The engine also features a high pressure common rail fuel system, which dramatically reduces engine noise while providing more responsive power and better fuel efficiency at every rpm.

Fortens models, with the Kubota V3600 engine, are available with an Electronic Powershift transmission only, featuring either one or two speeds.

Fortens Advance models feature the electronically controlled **DuraMatch™ transmission**, with one and two speeds respectively, providing:

- **Auto Deceleration System (ADS)** automatically slows the truck when the accelerator pedal is released, and finally brings the truck to a stop, which helps to significantly extend brake life. In addition, this feature assists the driver to accurately position the truck in front of a load. There are 10 ADS settings, programmable via the dash display by a service technician, which deliver different braking characteristics, from very gradual to aggressive, to suit the needs of the application.
- **Controlled Power Reversal;** the Pacesetter VSM™ controls the transmission to deliver smooth direction changes. The VSM reduces the throttle to slow the engine, initiates auto-deceleration to stop the truck, changes the transmission direction automatically and increases the throttle to accelerate the truck. The system virtually eliminates

tyre spin and shock loads on the transmission and significantly increases tyre life. As with ADS, the system is programmable via the dash display by a service technician, with settings from 1 to 10, to suit the needs of the application.

- **Controlled Roll-Back on Ramp;** the transmission controls the rate of descent of the truck on a ramp, when the brake and throttle pedal are released, to provide maximum control on a grade and increase operator productivity.

The Fortens Advance+ models feature the electronically controlled two-speed extended function **DuraMatch™ Plus2 transmission**. This transmission, in addition to the above, features:

- **Throttle Response Management** allows the operator to manage his travel speed, according to the position of his foot on the accelerator pedal. For example, a certain speed can be maintained both on the flat and on a gradient, without the need to depress the pedal further. The system also compensates for hydraulic operation and drawbar pull.
- **Dynamic Auto Deceleration System;** as with the DuraMatch™, the operator can slow the truck down without using the brake and the rate of braking is determined by the dashboard settings 1-10. In addition, thanks to the Throttle Response Management feature, the rate of deceleration can be further fine-tuned according to the rate at which the driver releases his foot from the accelerator pedal.
- **Auto-Speed Hydraulics with Automatic Inching Control;** when lifting a load, the engine speed is automatically increased to provide full hydraulic power. The Pacesetter VSM™ maintains the current travel speed (or prevents travel) until operator steps on accelerator. No operator inching is required and productivity is increased by simplifying operator actions.
- **First Gear** offers **Increased Drawbar Pull** for use on gradients.
- **Second Gear** provides maximum engine efficiency in applications where longer travel distances are common.

The transmissions are compatible with the combi-cooler radiator and a superior counterweight tunnel design coupled with a “pusher” type fan, to provide the industry’s best cooling.

The available Oil-immersed brakes offer reduced maintenance & repair time and costs, which results in extended truck dependability and uptime.

Trucks fitted with Oil-immersed brakes are ideally suited to applications in wet, dirty or corrosive environments, and ensure consistent braking performance over the lifetime of the truck. This is thanks to the sealed unit that houses and protects the brakes, so preventing contaminants and damage.

All powertrains are controlled, protected and managed by The **Pacesetter VSM™** industrial onboard computer, featuring a CANbus communications network.

This system permits adjustment and optimisation of the truck's performance, in addition to monitoring key functions. It enables quick, easy diagnostics, minimizing repair downtime and unnecessary parts swapping.

Hassle-Free Hydraulic systems, featuring Leak-free O-ring face seal fittings reduce leaks for enhanced reliability.

Non-mechanical, Hall-Effect sensors and switches have been fitted and are designed to outlast the life of the truck.

Load Sensing Hydraulics (LSH), where available, deliver increased operational efficiency, providing a 15% reduction in fuel consumption on the VDI cycle, with no loss in productivity*. Variable displacement piston pumps match the flow rate and lifting speed continuously to the demands of the duty cycle. The engine therefore supplies only power to the hydraulic pumps when required, so more power is available for driving. This provides increased responsiveness and acceleration, which increases productivity and lowers fuel consumption, reducing overall operating costs.

LSH also offers an ECO-eLo (Fuel Efficiency) mode, reducing engine speed by 20% and optimising throttle response, so that the truck operates in the most economical power range. This results in a reduction in fuel consumption of up to 20%* but has a limited effect on overall truck productivity under application conditions. The ECO-eLo mode also delivers lower noise levels by up to 3dB(A). If a faster work rate, or higher productivity is required, the truck can easily be reprogrammed to HiP (High Performance) mode of operation through the dash display, with access secured by a unique customer password.

(*Hyster Productivity Test Cycle: Load Sensing Hydraulics and ECO-eLo functions are available on trucks with TouchPoint mini-levers and DuraMatch transmissions).

The operator compartment features class-leading **Ergonomics** for maximum driver comfort and productivity.

- Operator space is optimised, thanks to a new overhead guard design and significantly more floor space.
- The Easy-to-use 3-point entry design of operator compartment has an open non-slip step with a height of just 42.5 cm.
- The new FLM80 Full Suspension Seat together with the isolated powertrain provide best in class Whole-Body Vibration levels of 0.6m/s², ensuring that the operator remains comfortable throughout the shift and fatigue, aches and pains are kept to a minimum.
- The new mini-lever armrest features a new contoured design, and - in addition to the hydraulic functions - features a horn and direction switch, ensuring that all key truck functions are within constant, easy reach.
- The Rear grab handle with horn button facilitates reverse driving.
- An infinitely adjustable steering column, 30 cm diameter steering wheel with spinner knob and full-suspension seat enhance driver comfort.

The Hyster Fortens is the fastest and easiest lift truck to **Service**.

- Complete cowl-to-counterweight service access and simplified layout of wiring and hydraulics offers greater access to components, which in turn decreases service time for unscheduled repairs and regular maintenance.
- Fast, colour-coded daily checks and diagnostic systems can be managed via the dash display.
- An Engine coolant change and Hydraulic oil change interval of 4 000 hours also contributes to reduced downtime.





Strong Partners, Tough Trucks, for Demanding Operations, Everywhere.

Hyster supplies a complete range of warehouse equipment, IC and electric counterbalanced trucks, container handlers and reach stackers. Hyster is committed to being much more than a lift truck supplier.

Our aim is to offer a complete partnership capable of responding to the full spectrum of material handling issues: Whether you need professional consultancy on your fleet management, fully qualified service support, or reliable parts supply, you can depend on Hyster.

Our network of highly trained dealers provides expert, responsive local support. They can offer cost-effective finance packages and introduce effectively managed maintenance programmes to ensure that you get the best possible value. Our business is dealing with your material handling needs so you can focus on the success of your business today and in the future.



Hyster Europe

Flagship House, Reading Road North, Fleet, Hants GU51 4WD, England.

Tel: +44 (0) 1252 810261



www.hyster.eu



infoeurope@hyster.com



[/HysterEurope](https://www.facebook.com/HysterEurope)



[@HysterEurope](https://twitter.com/HysterEurope)



[/HysterEurope](https://www.youtube.com/HysterEurope)



HYSTER  and FORTENS are registered trademarks in the European Union and certain other jurisdictions.

MONOTROL is a registered trademark, and DURAMATCH and  are trademarks in the United States and in certain other jurisdictions.

Hyster products are subject to change without notice. Lift trucks illustrated may feature optional equipment.