

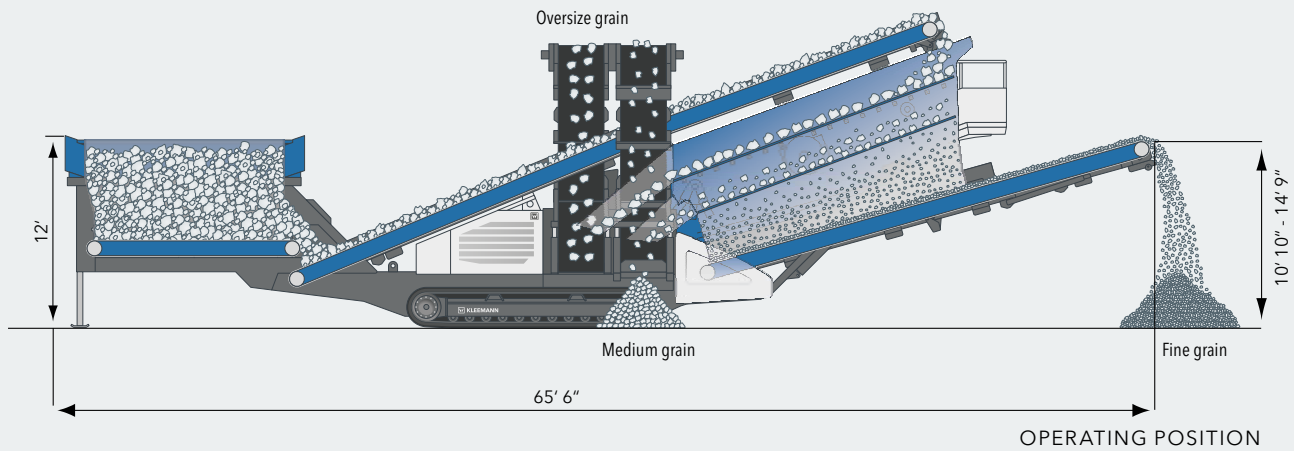

TECHNICAL INFORMATION | MOBILE SCREENING PLANTS

MOBISCREEN MS 952i EVO





TECHNICAL HIGHLIGHTS

- Mobile double-deck screening unit
- Diesel-hydraulic drive
- Classifying screen
- Maximum feed size 3.94" x 6.3"

TECHNICAL INFORMATION MS 952i EVO

Feeding unit

Feed capacity up to approx. (US t/h)	551
Max. feed size (inch)	4" x 6.3" ¹⁾
Feed height - foldable slotted grate (inch)	11' 10"
Hopper volume (yd ³)	10.5

Hopper discharge belt

Width x Length (inch)	3' 11" x 11' 6"
-----------------------	-----------------

FEEDING CONVEYOR

Width x Length (inch)	3' 11" x 39' 4"
-----------------------	-----------------

Screening unit

Type	Double-deck classifying screen
Width x Length (inch)	5' 1" x 20'

Fine grain discharge conveyor

Width x Length (inch)	3' 11" x 26' 7"
Discharge height approx. (inch)	10' 10" - 14' 9"

Side discharge conveyor, right

Width x Length (inch)	2' 8" x 33' 6"
Discharge height approx. (inch)	16' 5"

Side discharge conveyor, left

Width x Length (inch)	2' 8" x 33' 6"
Discharge height approx. (inch)	16' 5"

Power supply unit

Drive concept	Diesel-hydraulic
MS 952: Deutz (Tier 3/Stage IIIA) (hp)	117
MS 952i: Deutz (Tier 4f/Stage IV) (hp)	132

Transport

Transport height approx. (inch)	11' 1"
Transport length approx. (inch)	58' 11"
Transport width approx. (inch)	9' 10"
Transport weight of basic plant - max. configuration (lbs)	72,750 - 89,300

¹⁾ with vibrating grate



MOBISCREEN MS 952i EVO

As a double-deck classifying screen, the mobile screening plant MOBISCREEN MS 952i EVO is equipped with a 9.5 m² screen casing. The plant impresses with a feed capacity of up to 551 US t/h. It is controlled using a modern control system. As a result, all functions are easy to control and operating statuses and machine functions can be viewed at any time.

STANDARD EQUIPMENT

- Double-deck classifying screen
- 10.5 yd³ hopper unit
- Foldable grate, gap width 4", can be folded hydraulically (small remote control)
- Feeding conveyor, smooth belt
- Side discharge conveyors, belt width 2' 8", max. discharge height 16' 5"
- Fine grain discharge conveyor, belt width 3' 11", max. discharge height 14' 9"

- Removable, wired machine control system with the functions: crawler chassis, operation of crusher discharge conveyors and foldable grate (transport and production position), automatic mode, emergency off function, moving support feet in/out, tilt adjustment of fine grain conveyor and screen casing, moving and lifting the feeding conveyor, speed setting of hopper discharge conveyor, side discharge conveyors

OPTIONS

- 13 yd³ hopper unit
- Wear lining made from wear-resistant steel (KRS) or rubber (for 10.5 yd³ and 13 yd³)
- Vibrating grate for separating feed material, gap width of upper deck 4", gap width of lower deck 1.26" - 3.54"
- Dosing shutter on hopper unit for continuous material flow
- Feeding conveyor, rubber cleaned belt prevents material rolling back
- Material brake for feeding conveyor prevents material rolling back
- Material brake for screen prevents feed material leaping from the upper deck
- Belt cover for the feeding conveyor or fine grain discharge conveyor
- External power supply - for efficient mains operation, possible to change between two energy sources: own propulsion (diesel engine) or external power supply
- Start-Stop system (only for Tier 4f engines) for low consumption in idle phases
- Radio remote control: crawler chassis, slotted grate, emergency stop
- Remote control for foldable grate, in addition to cable control (omitted if plant has radio remote control)
- Line coupling for interlinking with other KLEEMANN plants
- Large selection of screen surfaces for all screens with different mesh widths
- Straps with knocking elements for use with sticky material
- Water spray system for dust reduction
- Lighting, halogen or LED



SPARE PARTS

Efficient operation of the machine also requires the selection of the right wear parts. The KLEEMANN original parts are optimally designed for the requirements of users and the machine. They are characterized by a long service life, excellent quality, good availability, and simple assembly. With application know-how and expertise and competent advice, we help our customers to find the optimal wear part for their individual application.

APPLICATION-DEPENDENT WEAR PARTS

<p>Screen surfaces</p>		<ul style="list-style-type: none"> ☑ Screen surfaces available in different mesh shapes, wire qualities and thickness: <ul style="list-style-type: none"> > Square mesh > Rectangular mesh > Harp screens (G-harp, W-harp, S-harp, Varia harp)
<p>Scraper ledges</p> <p>Front scrapers</p> <p>Wedge strippers</p>		<ul style="list-style-type: none"> ☑ Wedge strippers to protect the conveyor belts ☑ Reduction in wear with abrasion-resistant plastics ☑ Precise scrapers guarantee less material loss ☑ Available for: <ul style="list-style-type: none"> > Side discharge conveyor (no front scraper, instead rapper pulley) > Fine grain discharge conveyor > Feeding conveyor, smooth > Hopper discharge conveyor > Cleated belt (no front scraper, instead rapper pulley) > Feeding conveyor, cleated belt (no front scraper, instead rapper pulley)
<p>Conveyor belts</p>		<ul style="list-style-type: none"> ☑ Closed, multilayer conveyor belts are suitable for all requirements and increase the capacity of plants ☑ Cleated belts with solid rubber edges ensure optimal material handling ☑ Elastic rubber pads mute impacts from different materials ☑ Smooth version or cleated belt
<p>Conveyor belt rollers</p>		<ul style="list-style-type: none"> ☑ High-quality rollers in the belt conveyors for transporting heavy material ☑ Simple maintenance on site thanks to easily replaceable rollers ☑ Available in different versions: <ul style="list-style-type: none"> > Support roller for feeding > Lateral guide roller > Return roller

More information can be found online at www.partsandmore.net or in our Parts and more catalog