

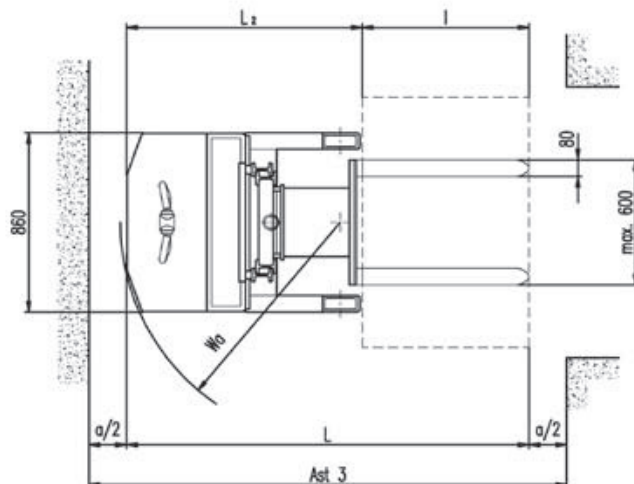

1 Frenatura / Braking
2 Marcia / Running

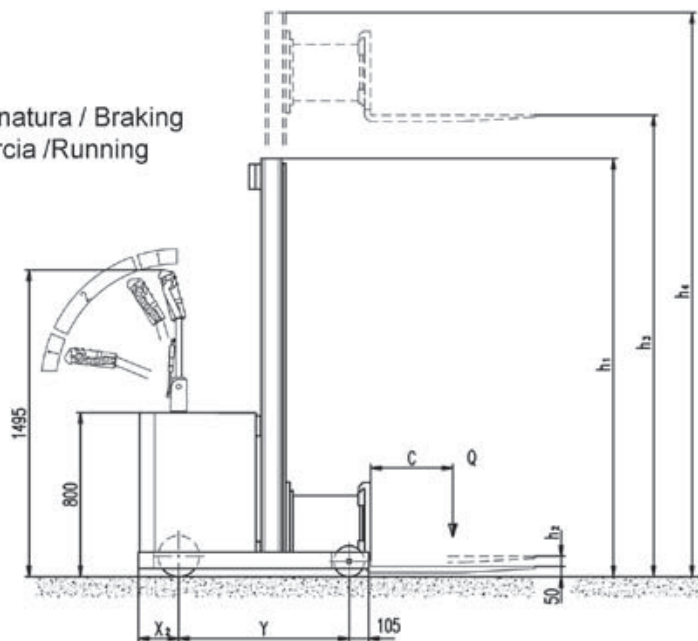

MOD.	RIFERIMENTO / REFERENCE												
	Q	C	L	X2	Y	L2	h3	h2	h1	l	a	h4	Wa
SC 08/16	800	400	1930	195	830	1130	1600	-	2040	800	200	2040	1055
SC 08/25	800	400	1930	195	830	1130	2500	50	1790	800	200	3000	1055
SC 08/30	800	400	1930	195	830	1130	3000	50	2040	800	200	3500	1055

CATEGORIE FEATURES	1 Modelli / Models		Semovente contrappesato / Electric counterbalanced pallet stacker	SC 08/16	SC 08/25	SC 08/30
	2 Alimentazione / Feed		Elettrico (batteria) / Electric (battery)	si / yes		
	3 Guida / Steering		Timone / Handle (.) - Volantino / Steering wheel (..)	(.)		
4 Brandeggio / Tilting		Avanti / Forward(alfa) - Indietro / Backward(beta)	—			
5 Stabilità / Stability		Secondo 89/240/CEE / Conforming 89/240/CEE	si / yes			
6		Traslazione con/senza carico/Travelling with/without load	km/h	4.2 / 5.3	4.2 / 5.1	
7 Velocità / Speeds		Elevazione con/senza carico / Lifting with/without load	m/s	0.11 / 0.18		
8		Discesa con/senza carico / Lowering with/without load	m/s	0.26 / 0.22		
9 Forza trazione/Traction capacity		Con/senza carico with/without load	daN	—		
10 Pendenza / Gradeability		Con/senza carico with/without load	%	—		
11 Peso / Weight		Carrello senza batteria / Truck without battery	(~ daN) kg	905	1005	1050
12 Reazione sugli assi / Axle load		Con carico davanti/dietro / With load front/rear	daN	—		
13 Corridoio stivaggio / Aisle width		Ast3 con / with pallet 800x1200	mm	2130		
14		Quantità (x motrice) davanti/dietro / Number (x drive) front/rear		x / 2		
15 Ruote / Wheels		Dimensioni / Dimensions anteriori / front	mm	Ø 200x85		
16		Dimensioni / Dimensions posteriori / rear	mm	Ø 150x50		
17 Scartamento / Gauge		Davanti/dietro / Front/rear	mm	— / 780		
18 Luci / Underclearance		Carrozzeria / Body	mm	40		
19		Forche / Forks	mm	—		
20 Freni / Brakes		Elettromagnetico / Electromagnetic		si / yes		
21		Tipo tubetti corazzata / Type protected tubes		si / yes		
22 Batteria / Battery		Volts / Ah(con scarica in 5 ore) / (5 hr. discharge)	V/Ah	24 / 160 - 230		
23		Peso / Weight	kg	180 / 225		
24 Motori elettrici / Electric motors		Potenza trazione / Traction power (KB 60)	W	1000		
25		Potenza sollevamento / Lifting power (ED 15%)	W	2000		
26 Accelerazione / Speed variation		Elettronico / Electronic		si / yes		
27 Trasmissione / Transmission		Ingranaggi in bagno d'olio / With oil bath gears		si / yes		

Sede Legale / Registered office: viale Milano, 8
36041 ALTE di MONTECCHIO M. (VICENZA)
Tel. 0444/696466 r.a. Fax 0444/695406
Stabilimento / Plants: via A. De Gasperi, 3/5
36040 BRENDOLA (VICENZA)
Tel. 0444/400970 Fax 0444/401333
E-mail: carrelli@cvtalia.com
Azienda certificata UNI EN ISO 9001

